

Serial No.	H-A069-E-08
------------	-------------

Ball Valve Type21·21α Pneumatic Actuated Type AR 15~100mm(1/2"-4")

User's Manual





Contents

1. Be sure to read the following warranty clauses of our product	1
2. General operating instructions	2
3. General instructions for transportation, unpacking and storage	3
4. Name of parts	4
5. Maximum working pressure vs. Temperature	7
6. Specifications of valves	9
7. Specifications of actuator	9
8. Specifications of filter regulator	10
9. Specifications of solenoid valve	10
10. Specifications of limit switch box	11
11. Specifications of speed controller	12
12. Installation procedure	13
Flanged end	14
Threaded end	15
Socket end (PVC, C-PVC)	16
Socket end (PP, PVDF)	17
Spigot end (PP, PVDF)	17
13. Support setting procedure	18
14. Air piping procedure	19
15. Connection of limit switch procedure	21
16. Connection of solenoid valve procedure	22
17. Operating procedure	23
1) Operating procedure by air	23
2) Manual operation procedure	24
3) Adjustment of opening / closing speed procedure	25
4) Full opening adjustment procedure	27
18. Mounting insert-metal and base	28
19. Actuator removal procedure	30
20. Method of adjusting face pressure between ball and seat	32
21. Disassembling method for replacing parts	33
22. Inspection items	34
23. Troubleshooting	35
24. How to inquire about defects or replacement	36
25. Handling of residual and waste materials	36



This user's guide contains very important information for the proper installation, maintenance and safe use of an ASAHI AV Product.

Please store this manual in an easily accessible location.

<Warning & Caution Signs>

 Warning	<p>This symbol reminds the user to take caution due to the potential for serious injury or death.</p>
 Caution	<p>This symbol reminds the user to take caution due to the potential for damage to the valve if used in such a manner.</p>

<Prohibited & Mandatory Action Signs>







	<p>Prohibited: When operating the valve, this symbol indicates an action that should not be taken.</p>
	<p>Mandatory action: When operating the valve, this symbol indicates mandatory actions that must be adhered to.</p>

1. Be sure to read the following warranty clauses of our product



- Always observe the specifications of and the precautions and instructions on using our product.
- We always strive to improve product quality and reliability, but cannot guarantee perfection. Therefore, should you intend to use this product with any equipment or machinery that may pose the risk of serious or even fatal injury, or property damage, ensure an appropriate safety design or take other measures with sufficient consideration given to possible problems. We shall assume no responsibility for any inconvenience stemming from any action on your part without our written consent in the form of specifications or other documented approval.
- The related technical documents, operation manuals, and other documentation prescribe precautions on selecting, constructing, installing, operating, maintaining, and servicing our products. For details, consult with our nearest distributor or agent.
- Our product warranty extends for one and a half years after the product is shipped from our factory or one year after the product is installed, whichever comes first. Any product abnormality that occurs during the warranty period or which is reported to us will be investigated immediately to identify its cause. Should our product be deemed defective, we shall assume the responsibility to repair or replace it free of charge.
- Any repair or replacement needed after the warranty period ends shall be charged to the customer.
- The warranty does not cover the following cases:
 - (1) Using our product under any condition not covered by our defined scope of warranty.
 - (2) Failure to observe our defined precautions or instructions regarding the construction, installation, handling, maintenance, or servicing of our product.
 - (3) Any inconvenience caused by any product other than ours.
 - (4) Remodeling or otherwise modifying our product by anyone other than us.
 - (5) Using any part of our product for anything other than the intended use of the product.
 - (6) Any abnormality that occurs due to a natural disaster, accident, or other incident not stemming from something inside our product.

* Note that damage induced by a defect of our product is not covered by warranty.
- This guarantee applies to the use of our product only in Japan. If it is used overseas, please inquire with us separately.





2. General operating instructions

-   - Never attempt to disassemble an actuator.
- Warning  - Using a positive-pressure gas with our plastic piping may pose a dangerous condition due to the repellent force particular to compressible fluids even when the gas is under similar pressures used for liquids. Therefore, be sure to take the necessary safety precautions such as covering the piping with protective material. For inquiries, please contact us. For conducting a leak test on newly installed piping, be sure to check for leaks under water pressure. If absolutely necessary to use a gas in testing, please consult your nearest service station beforehand.
- A ball-type valve structurally has a dead space. Be careful of volatile liquids such as hydrogen peroxide solution (H₂O₂) and sodium hypochlorite (NaClO) because those liquids may turn into gas in the dead space and cause an abnormal rise of pressure in the valve. The gas that causes an abnormal rise of inner pressure thorough vaporization is compressible fluid. So, if the valve breaks, its fragments explosively scatter, and it is very dangerous.
-   - Do not step on or apply excessive weight on valve. (It can be damaged.)
- Caution  - Use the valve working pressure, working temperature, ambient temperature within an allowable range.
(The valve can be damaged or deformed by operating beyond the allowable range.)
- Keep the valve away from excessive heat or fire. (It can be damaged, or destroyed.)
 - Do not use the valve to fluid containing slurry. (The valve will not operate properly.)
 - Do not use AV valves in a place where they may become submerged in water.
 - Do not remove a dust-proof cap provided to piping port before piping work starts.
 - Be careful of the environment where the valve is installed. In particular, avoid places exposed to salty wind, corrosive gas, chemical solution, sea water, steam, etc.
 - Do not apply a great impact or vibration to the actuator.
(Any such practice may result in breakdown.)
 - Allow sufficient space for maintenance and inspection.
 - Select a valve material that is compatible with the media. For chemical resistance information, refer to “CHEMICAL RESISTANCE ON ASAHI AV VALVE”.
(Some chemicals may damage incompatible valve materials.)
 - Do not use the valve in conditions where the fluid may have crystallized.
(The valve will not operate properly.)
 - Keep the valve out of direct sunlight, water and dust. Use cover to shield the valve. (The valve will not operate properly.)
 - Be careful not to allow foreign matters, water droplets, oil, and other substances to enter from the air pipe opening and intake/exhaust hole of the actuator. (In areas that are likely to have snow, melted water of snow that falls on the valve may enter from the air pipe opening and intake/exhaust hole of the actuator.)
 - Perform periodic maintenance. (Leakage may develop due to temperature changes or over periods of prolonged storage, rest or operation.)
 - When installing the valve, provide an appropriate support. (Failure to do so may cause breakage due to excessive force applied to the valve body and pipes.)
 - The AV valves must be used within the specifications specifically applicable to the product.
(May not work.)

General operating instructions (continued)

- If the actuator is used in an environment below 5°C temperature, its operating fluid must be free from the water and moisture contained in it because of possible problems due to the freeze.
- When you use the valve in a low-temperature environment, put a cover or such that covers the entire actuator to prevent it from freezing, and check the operating conditions on a regular basis. (If it freezes, it does not operate normally.)
- Use dehumidified and dust-removed clean operation air. When using highly dry air at a dew point of -40°C or less, please consult us separately.
-   - When removing the actuator, be sure to use the "Base plate removing jig". (Failure to so may cause, damage the Base plate.)
- Regarding the ball valve type, we recommend that you use fully open or fully closed. This is because the edge of the ball opening remains on the seat (PTFE) when used at an intermediate opening, so that the sealing performance temporarily deteriorates at the time of full closing.

3. General instructions for transportation, unpacking and storage

-   - When suspending and supporting a valve, take care and do not stand under a suspended valve.
-   - This valve is not designed to handle impacts of any kind. Avoid throwing or dropping the valve.
- Avoid scratching the valve with any sharp object.
- Do not over-stack cardboard shipping boxes. Excessively stacked packages may collapse.
- Avoid contact with any coal tar creosote, insecticides, vermicides or paint. (These chemicals may cause damage to the valve.)
-  - Store products in their corrugated cardboard boxes. Avoid exposing products to direct sunlight, and store them indoors (at room temperature). Also avoid storing products in areas with excessive temperatures. (Corrugated cardboard packages become weaker as they become wet with water or other liquid. Take care in storage and handling.)
- After unpacking the products, check that they are defect-free and meet the specifications.

4. Name of parts

15-50mm (1/2"-2")

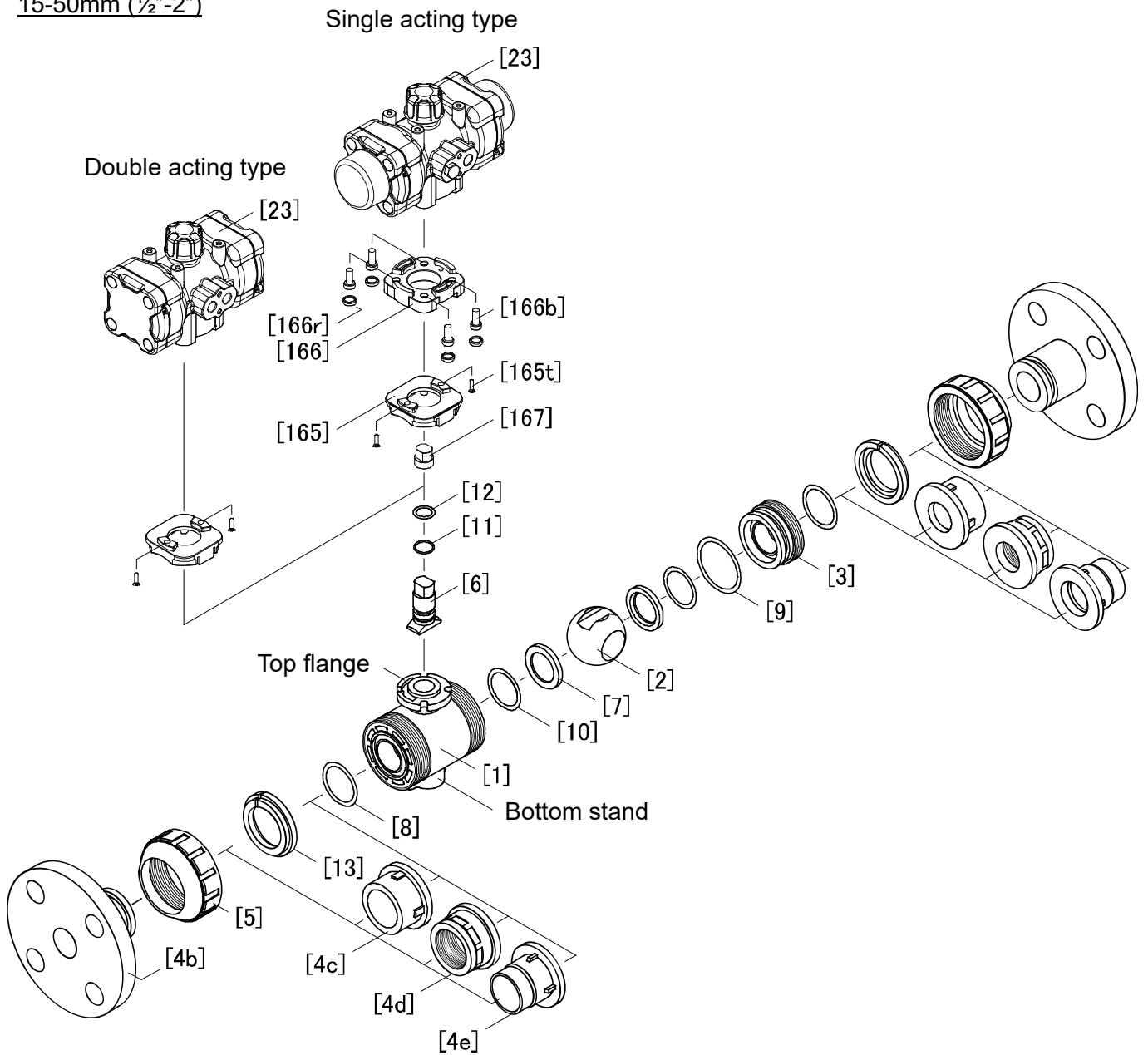

[1]	Body ^{*1}	[6]	Stem ^{*1}	[23]	Actuator
[2]	Ball ^{*1}	[7]	Seat ^{*1}	[165]	Base plate
[3]	Carrier ^{*1}	[8]	O-ring (A)	[165t]	Tapping screw
[4b]	End connector (Flanged end)	[9]	O-ring (B) ^{*2}	[166]	Connector plate
[4c]	End connector (Socket end)	[10]	O-ring (C) ^{*2}	[166b]	Bolt
[4d]	End connector (Threaded end)	[11]	O-ring (D)	[166r]	Rubber cap
[4e]	End connector (Spigot end)	[12]	O-ring (E)	[167]	Shaft adapter
[5]	Union nut	[13]	Stop ring		

^{*1}. Type 21 and 21α have not compatible.

^{*2}. Type 21 and 21α have not all same parts to make one complete. For details, please consult with your nearest service station in advance.

65mm, 80mm (2½", 3")

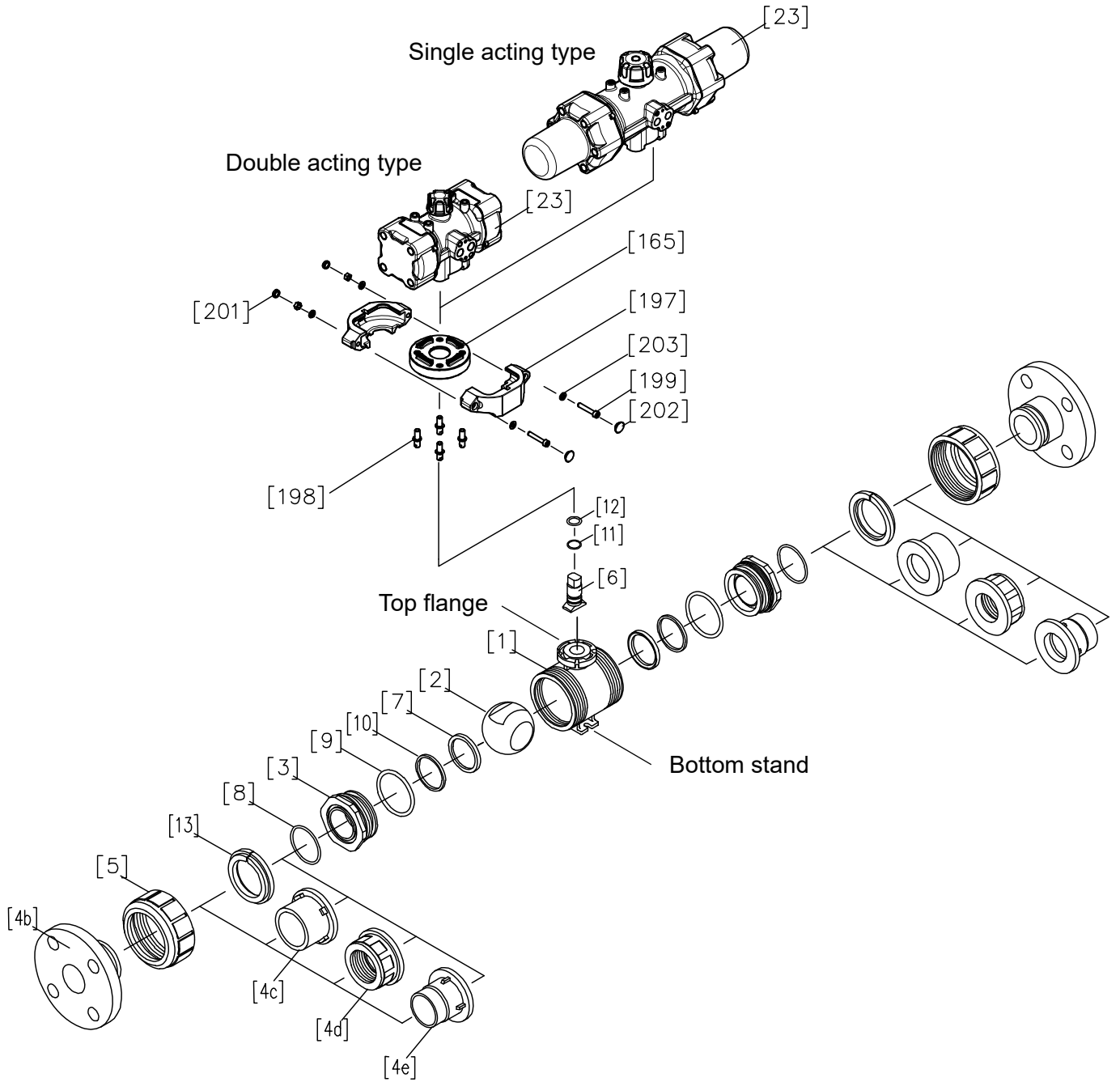

[1]	Body	[6]	Stem	[23]	Actuator
[2]	Ball	[7]	Seat	[165]	Base plate
[3]	Carrier	[8]	O-ring (A)	[197]	Cover plate
[4b]	End connector (Flanged end)	[9]	O-ring (B)	[198]	Bolt (with rib)
[4c]	End connector (Socket end)	[10]	Cushion	[199]	Bolt
[4d]	End connector (Threaded end)	[11]	O-ring (D)	[201]	Rubber cap
[4e]	End connector (Spigot end)	[12]	O-ring (E)	[202]	Rubber cap (with rib)
[5]	Union nut	[13]	Stop ring	[203]	Spring washer

100mm (4")

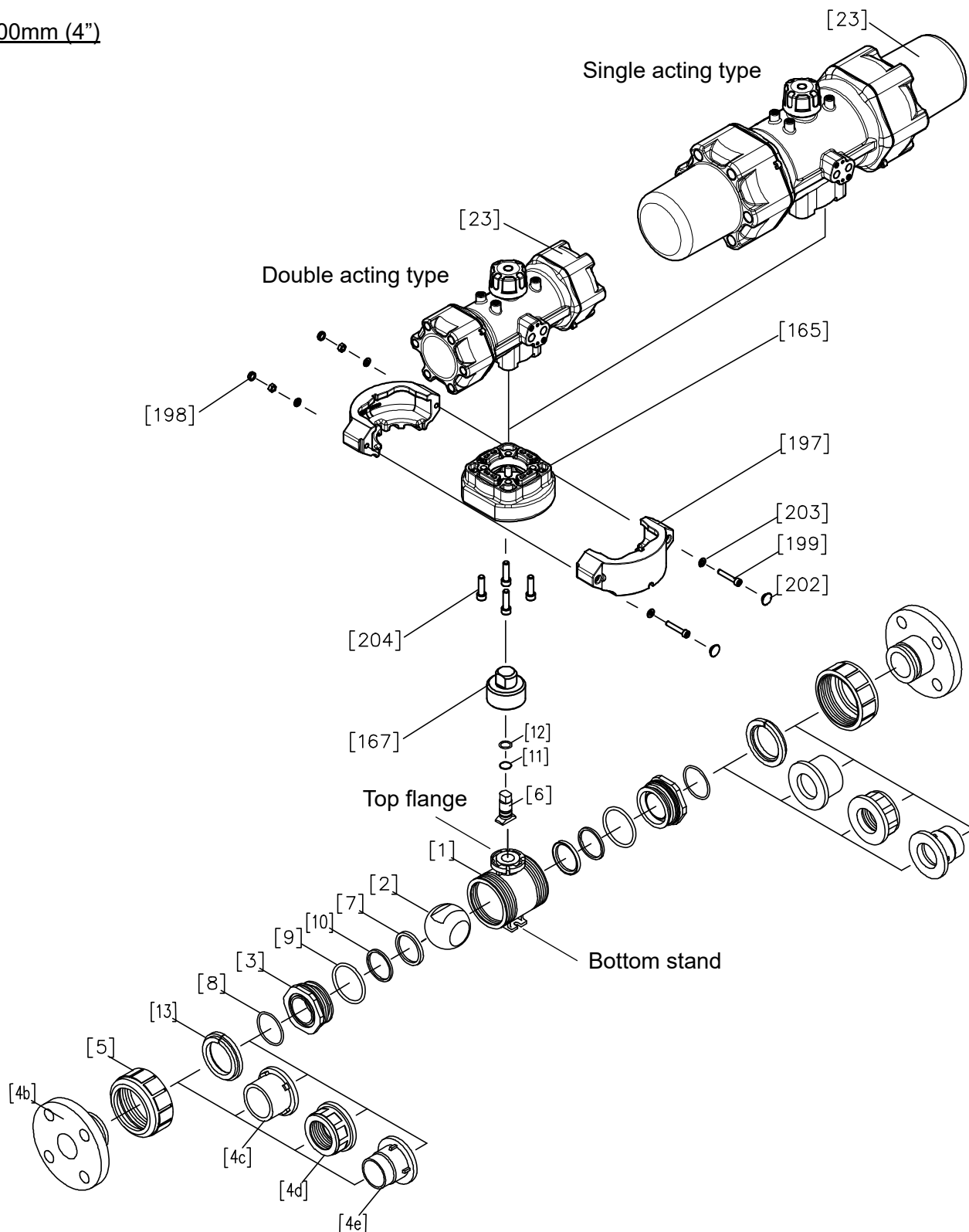

[1]	Body	[7]	Seat	[167]	Shaft adapter
[2]	Ball	[8]	O-ring (A)	[197]	Cover plate
[3]	Carrier	[9]	O-ring (B)	[198]	Bolt (with rib)
[4b]	End connector (Flanged end)	[10]	Cushion	[199]	Bolt
[4c]	End connector (Socket end)	[11]	O-ring (D)	[201]	Rubber cap
[4d]	End connector (Threaded end)	[12]	O-ring (E)	[202]	Rubber cap (with rib)
[4e]	End connector (Spigot end)	[13]	Stop ring	[203]	Spring washer
[5]	Union nut	[23]	Actuator		
[6]	Stem	[165]	Base plate		

5. Maximum working pressure vs. temperature

[JIS]

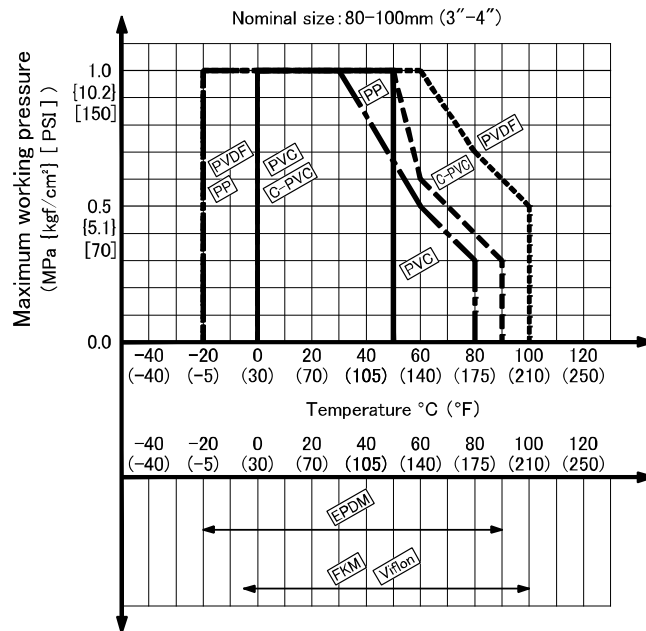
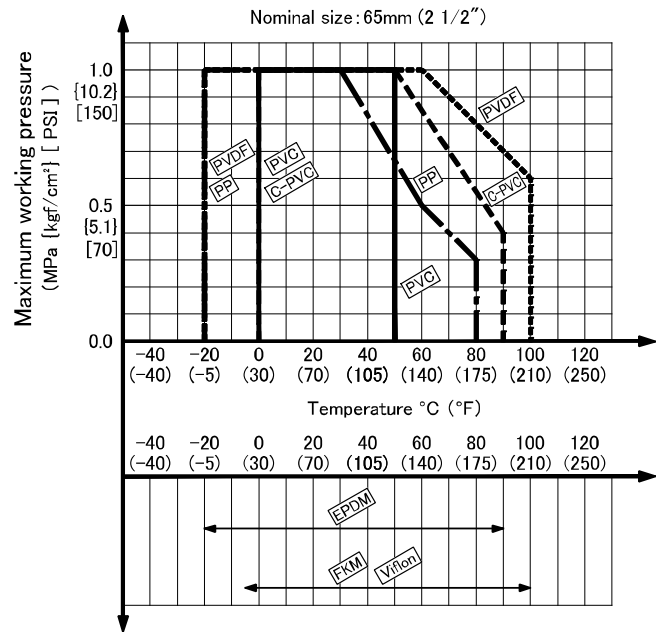
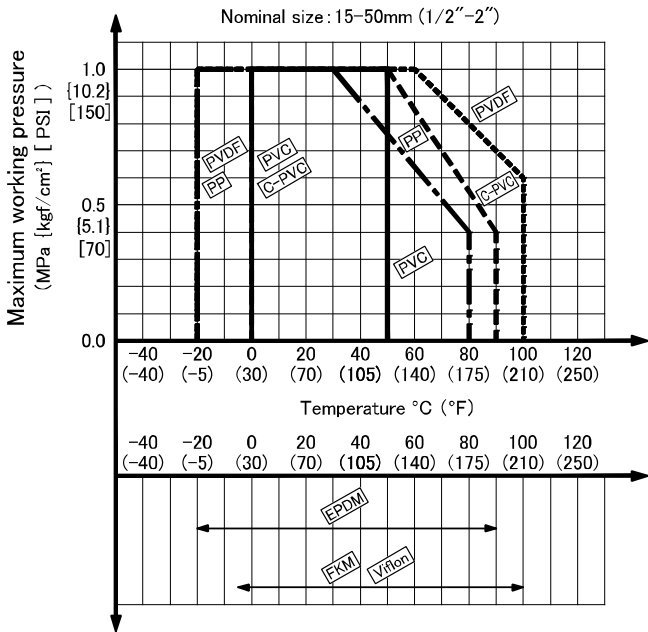

[ANSI, DIN]

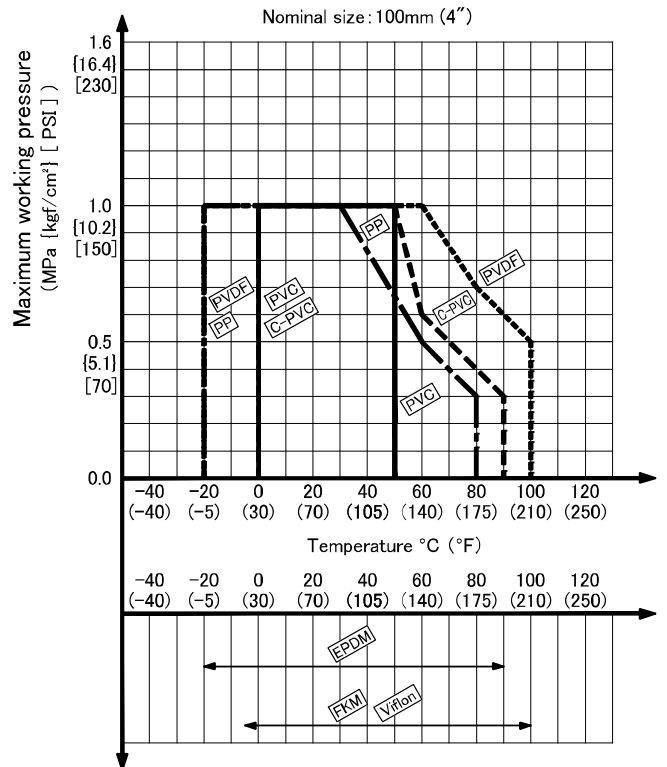
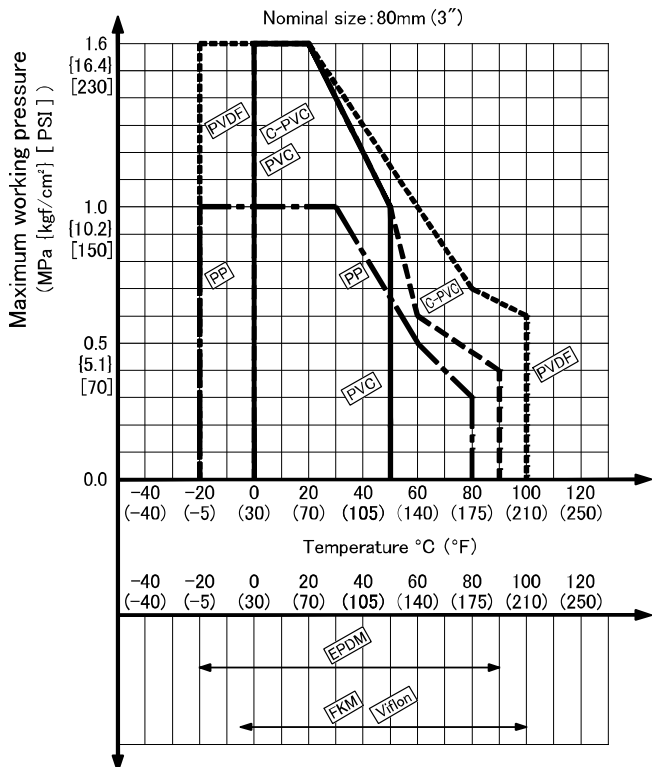
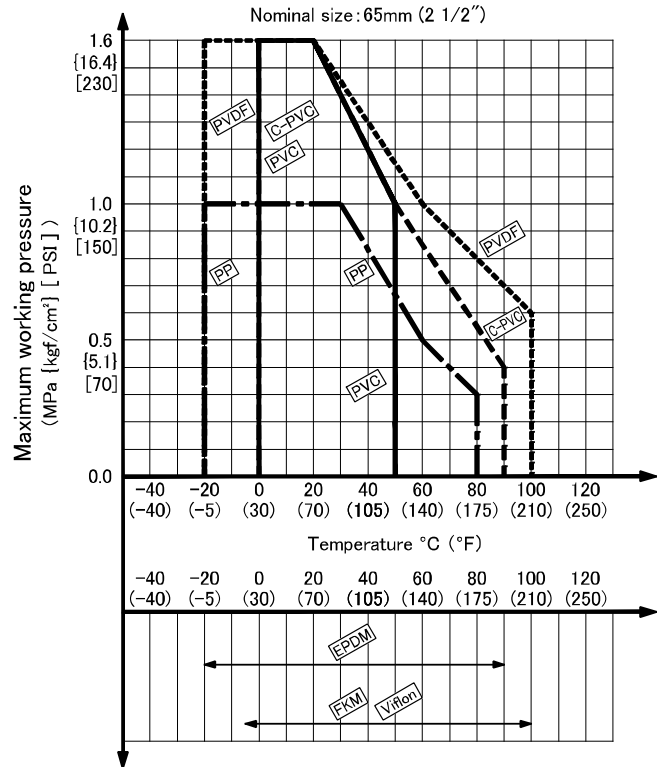
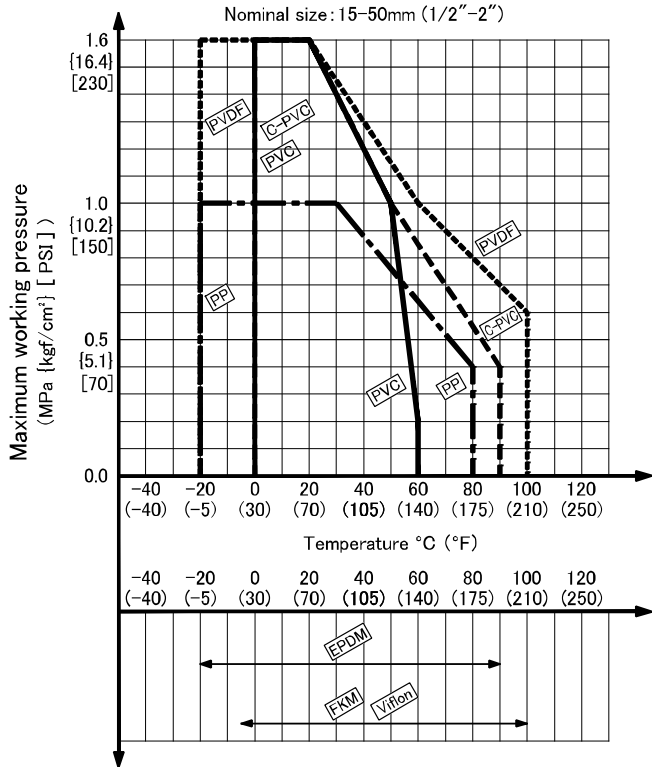

6. Specifications of valves

Nominal size \ Body material	PVC	C-PVC	PP	PVDF
	Type 21 α		Type 21	
15-50mm (1/2"-2")	Type 21 α		Type 21	
65-100mm (2 1/2"-4")	Type 21		Type 21	

* The model varies depending on the material of the valve body.

7. Specifications of actuator

Actuation	Nominal size	Actuator type	Air consumption NL per 1 open & close at 0.4MPa	Air supply bore
Double acting	15mm (1/2")	AR032DA10NN	0.3	Rc1/8
	20, 25mm (3/4"-1")	AR032DA11NN		
	32mm (1 1/4")	AR040DA20NN		
	40, 50mm (1 1/2"-2")	AR050DA30NN	1.3	Rc1/4
	65, 80mm (2 1/2"-3")	AR063DA10SN	1.8	
	100mm (4")	AR070DA40SN	5.1	
Air to open	15-25mm (1/2"-1")	AR040NC20SN	0.2	Rc1/8
	32mm (1 1/4")	AR050NC30SN	0.4	Rc1/4
	40, 50mm (1 1/2"-2")	AR063NC40SN	0.8	
	65, 80mm (2 1/2"-3")	AR070NC40SN	2.5	
	100mm (4")	AR100NC22SN	5.9	
Air to close	15-25mm (1/2"-1")	AR040NO20SN	0.2	Rc1/8
	32mm (1 1/4")	AR050NO30SN	0.4	Rc1/4
	40, 50mm (1 1/2"-2")	AR063NO40SN	0.8	
	65, 80mm (2 1/2"-3")	AR070NC40SN	2.5	
	100mm (4")	AR100NO22SN	5.9	

Actuation	Nominal size	Angle adjustment range*1	Standard operating pressure	Ambient temperature range
Double acting Air to open Air to close	15-100mm (1/2"-4")	Cannot adjust an angle	0.4-0.7 MPa {4.1-7.1 kgf/cm ² } [70-105 psi]	-10 to 60°C [14 to 150°F]

*1 ; A product without full opening adjustment mechanism cannot adjust an angle. A product with full opening adjustment mechanism can be adjusted to an arbitrary opening in a range between 0 and 45 deg. Refer to the page of "Full opening adjustment procedure" for the full opening adjustment method.

The color of the rubber cap is identified by red (standard color) for double acting and air to open, and black for air to close.

Rubber cap (Red)

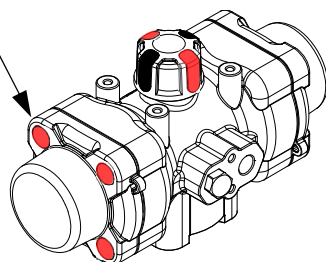

Double acting and Air to open

Rubber cap (Black)

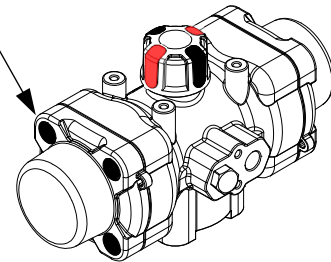

Air to close

8. Specifications of filter regulator

Actuation	Nominal size	Type sign	Air supply bore	Element rated filtration
Double acting Air to open Air to close	15-100mm (1/2"-4")	ARU2-02-8A-G	Rc1/4	5µm

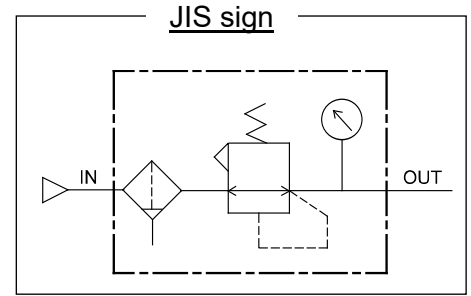

9. Specifications of solenoid valve

Actuation	Nominal size	Type sign	Power consumption
Double acting Air to open Air to close	15-100mm (1/2"-4")	4N3S102K-W□-G31193	AC: 6VA DC: 5.5W

Actuation	Air supply bore	Effective cross section	Additional functions
Double acting Air to open Air to close	Rc1/4	10mm ² or more	- Built-in bypass valve - Silencer with throttle valve attached (to be used as speed controller)

4N3S102K-W□-G31193

Sign	Protection level
W	Water tight cover type (Equivalent to IP 55)

Sign	Specification
1	100VAC 50/60Hz
(2)	110VAC 50/60Hz
3	200 AC 50/60Hz
(4)	220 AC 50/60Hz
5	24VDC
(6)	48VDC
(7)	100VDC
(8)	125VDC
(9)	110VDC

() is special order.

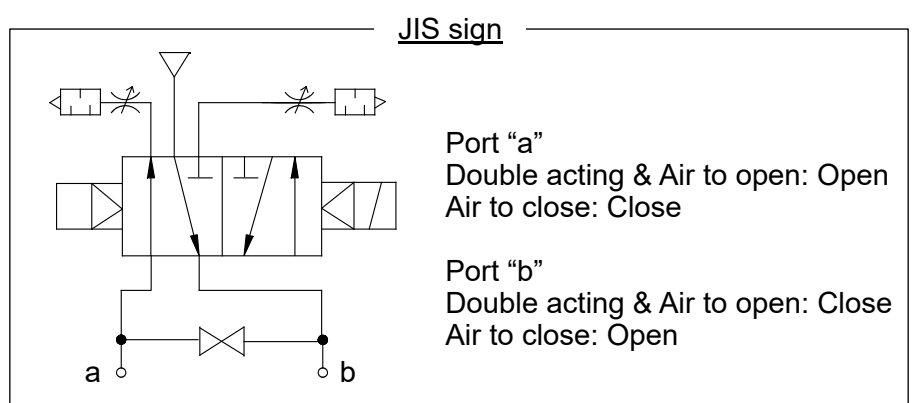
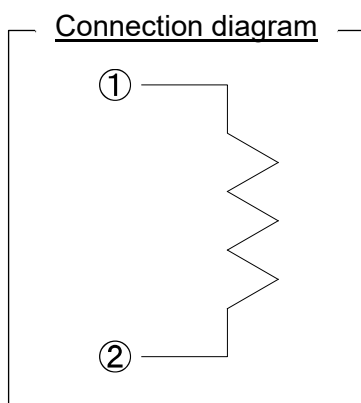

10. Specifications of limit switch box

Actuation	Nominal size	Type sign	Switch contact	Protection grade	Cable entries
Double acting Air to open Air to close	15-100mm (1/2"-4")	CFC-6301	Silver contact	IP67 (IEC529)	M20 × 1.5 cable gland (for cable φ6-12mm)
		CFC-6302	Gold contact (Micro-load)		

Ratings

Type sign	Rated voltage	Max current
CFC-6301	250VAC	10 A
	24VDC	2.5 A
CFC-6302	250VAC	0.1 A
	24VDC	0.1 A

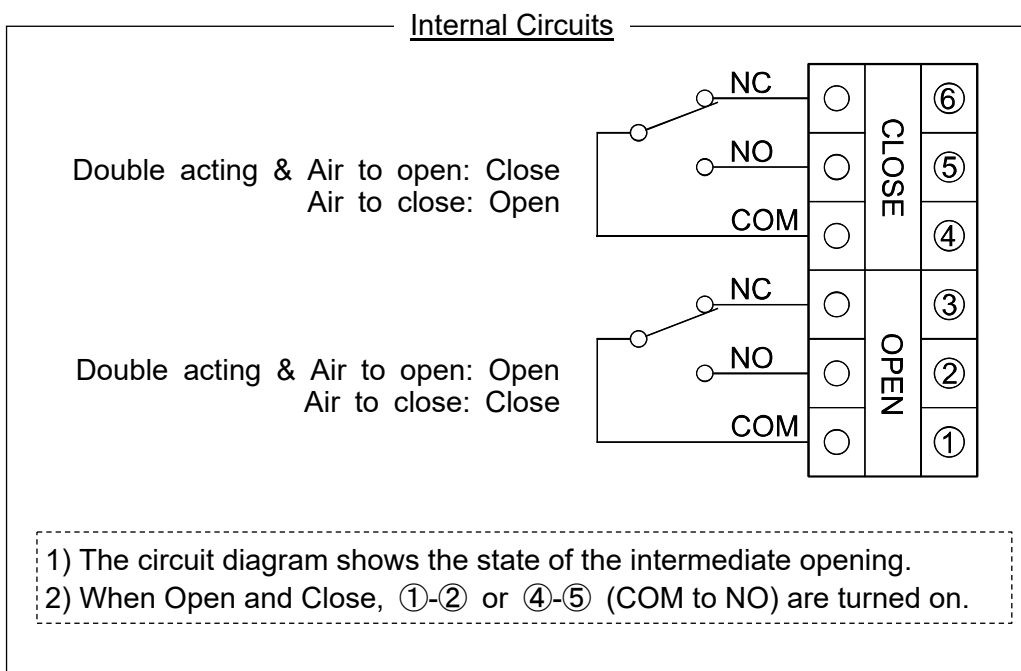

11. Specifications of speed controller

Actuation	Nominal size	Actuator type	Air supply bore	Type sign	Applicable tube outer diameter (mm)	Number of needle rotations
Double acting	15mm (1/2")	AR032DA10NN	Rc1/8	AS2201FG-01-06A	φ6	11 turns
	20, 25mm (3/4", 1")	AR032DA11NN				
	32mm (1 1/4")	AR040DA20NN				
Air to open Air to close	15-25mm (1/2"-1")	AR040NC20SN AR040NO20SN				
Double acting	40, 50mm (1 1/2", 2")	AR050DA30NN	Rc1/4	AS2201FG-02-06A	φ6	11 turns
	65, 80mm (2 1/2", 3")	AR063DA40SN				
	100mm (4")	AR070DA40SN				
Air to open Air to close	32mm (1 1/4")	AR050NC30SN AR050NO30SN				
	40, 50mm (1 1/2", 2")	AR063NC40SN AR053NO40SN				
	65, 80mm (2 1/2", 3")	AR070NC40SN AR070NO40SN				
	100mm (4")	AR100NC22SN AR100NO22SN				

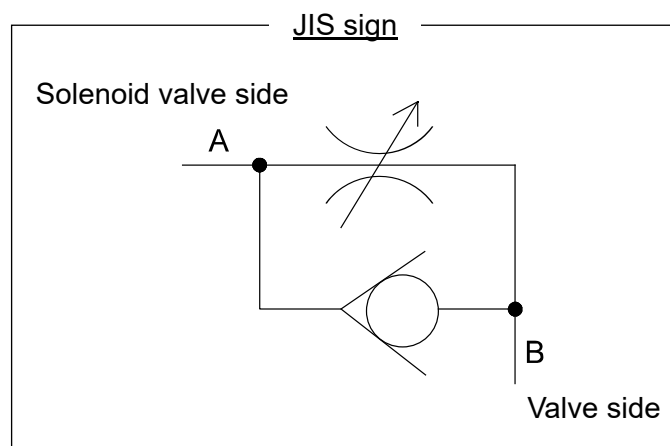

12. Installation procedure



Warning

- When suspending and supporting a valve, take care and do not stand under a suspended valve.



- Be sure to conduct a safety check on all hand and power tools to be used before beginning work.
 - When conducting piping work, wear personal protective equipment appropriate to the contents of work. (Failure to do so may cause an injury.)

- Take care not to over-tighten the Union nut. (The valve can be damaged.)

- Do not use the pipe wrench. (The valve can be damaged.)



- When installing pipes and valves, ensure that they are not subjected to tension, compression, bending, impact, or other excessive stress.

- When installing a piece of equipment at the end of the piping line, be sure to keep the secondary (Downstream) End Connector and Union nut installed on the valve.

- When installing Ball Valve, 15 to 50 mm (1/2" to 2") at the end, note the direction of flow.

Find the mark ◀ molded on the Carrier-side body. On the secondary (Downstream) side, the Carrier is integral with the valve body.

This is the preferred method if installation when installing the equipment at the end of the line for safety purposes.

- If the Carrier is loosened, retighten the Carrier.

- When installing, disassembling, or reassembling the piping, fix the End connector.

- Before a water test, be sure that the Union nut is tightly fastened.

- Fasten the Union nut while avoiding the parallelism and axial misalignment of the flange surface.

- When connecting a ASAHI AV Valve to metal piping, take care not to let the pipe stress on the ASAHI AV Valve.

- When screwing in a Metal Insert (Ensats), install it vertically. Refer to the User's Manual for Metal Insert (Ensats) by the maker.

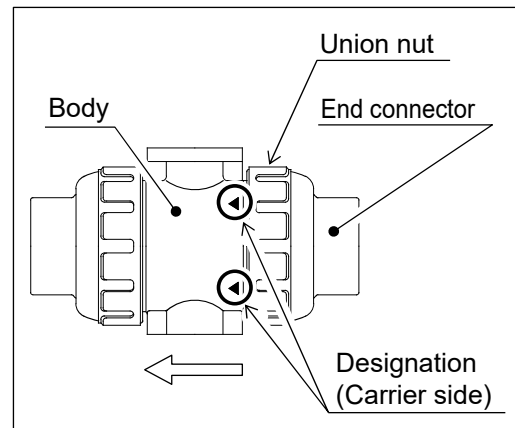

Flanged end (PVC, C-PVC, PP, PVDF)



- Use flat faced flanges for connection to AV Valves.
- Ensure that the mating flanges are of the same standards.
- Be sure to use sealing gaskets (AV Gasket), bolts, nuts, and washers and tighten them to specified torques. (When a non-AV gasket is used, a different tightening torque instruction should be followed.)

Necessary items

- Torque wrench
- AV gasket
- Spanner wrench
- Bolt, Nut, Washer for piping

Procedure

- 1) Set the AV gasket between the flanges.
- 2) Insert washers and bolts from the pipe side, insert washers and nuts from the valve side, then temporarily tighten by hand.



- The parallelism and axial misalignment of the flange surface should be under the values shown in the following table to prevent damage the valve. (A failure to observe them can cause destruction due to stress application to the pipe.)

Unit: mm {inch}

Nominal size	15-32mm (1/2", 1 1/4")	40-80mm (1 1/2"-3")	100mm (4")
axial misalignment	1.0 {0.04}	1.0 {0.04}	1.0 {0.04}
parallelism (a-b)	0.5 {0.02}	0.8 {0.03}	1.0 {0.04}

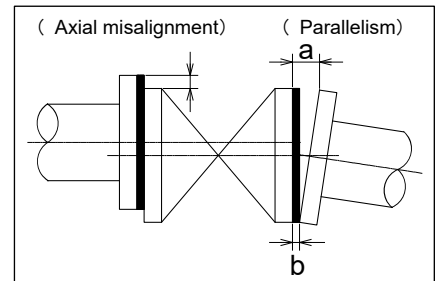

- 3) Tighten the bolts and nuts gradually with a torque wrench to the specified torque level in a diagonal manner. (Refer to Fig.12-1.)
- 4) Tighten it more than 2 turns clockwise with specified torque. (Refer to Fig.12-1.)



- Do not tighten above the specified torque value. (The valve can be damaged or leaks.)

Specified torque value

Unit: N-m {kgf-cm} [lb-inch]

AV gasket material	15, 20mm (1/2", 3/4")	25-40mm (1"-1 1/2")	50, 65mm (2", 2 1/2")	80, 100mm (3", 4")
PTFE coted	17.5 {179}	20.0 {204}	22.5 {230}	30.0 {306}
PVDF coted	[155]	[177]	[200]	[266]
Rubber	8.0 {82}	20.0 {204}	22.5 {230}	30.0 {306}
	[71]	[177]	[200]	[266]

Fig.12-1

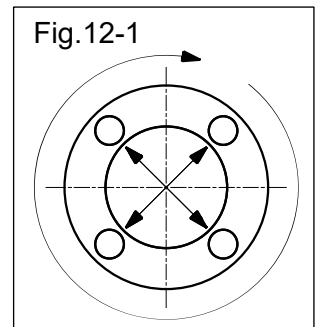



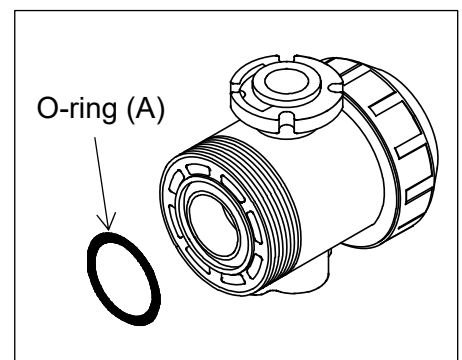

* When Union nut is loosened or removed, please install in the following way.

- 1) Make sure that the O-ring (A) is properly mounted to the body.
- 2) Set the End connector directly on the body without allowing the O-ring (A) to come off.
- 3) Tighten Union nut on each valve until hand tight.
- 4) Using a strap wrench tighten Union nuts uniformly on each side approx. 90°- 180°turns, 1/4 to 1/2 turns.



Threaded End (PVC, C-PVC, PP, PVDF)

- 

 - Avoid excessive tightening. (The valve can be damaged.)
- 

 - The Union nut of this product is fastened lightly so that it can be loosened easily. Be sure to remove the end connector before carrying out the work. (Failure to do so may cause external leakage.)
- Make sure that the threaded connections are plastic x plastic. (Metallic thread can cause damage.)
- Wrap the threaded joints on our plastic piping with sealing tape. Using a liquid sealing agent or liquid gasket may cause stress cracks (Environmental Stress Cracking). Our product warranty shall not apply in case of said use, even when said use is unavoidable.

Necessary items



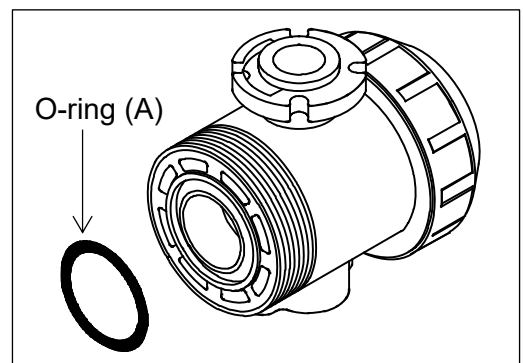
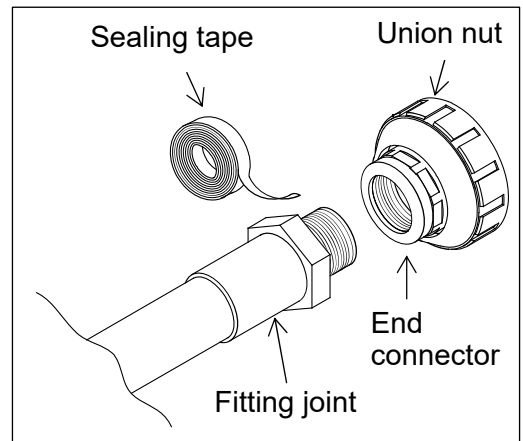



- Sealing tape
- Strap wrench
- Spanner wrench or Motor wrench

Procedure

- 1) Wind a sealing tape around the external thread of joint, leaving the end (about 3mm) free.
- 2) Loosen the Union nut with a strap wrench.
- 3) Remove the Union nut and the end connector.
- 4) Tighten the external thread of the joint and the end connector hardly with hand.
- 5) Using a spanner wrench or motor wrench, screw in the end connector by turning 180° -360° carefully without damaging it.
- 6) Make sure that the O-ring (A) is properly mounted to the body.
- 7) Set the End connector directly on the body without allowing the O-ring (A) to come off.
- 8) Tighten Union nut on each valve until hand tight.
- 9) Using a strap wrench tighten Union nuts uniformly on each side approx. 90° - 180° turns, 1/4 to 1/2 turns.



Socket end (PVC, C-PVC)

-  - When using an adhesive, ventilate the space sufficiently, prohibit the use of a fire in the vicinity, and do not inhale adhesive vapors directly.
-  - If an adhesive gets into contact with your skin, wash it off immediately. If you feel sick or find anomaly, receive a physician's diagnosis and take appropriate measures promptly.
-  - Do not under any circumstances try to insert a pipe into another fitting or valve by striking it. (Which may break the piping.)
-  - Take care in doing work at low temperatures. Solvent vapors are hard to evaporate and are likely to remain. (Solvent cracks may occur, damaging the equipment.)
After assembling the piping system, open both ends of the piping and use a fan (of the Low-Voltage Type) or something similar to ventilate the space, thus removing the solvent vapors.
- Do not apply more adhesive than necessary. (The valve can be damaged due to solvent cracking.)
-  - The Union nut of this product is fastened lightly so that it can be loosened easily. Be sure to remove the End connector before carrying out the work. (Failure to do so may cause external leakage.)
-  - Use the appropriate Asahi AV cement.
- Conduct a water test at least 24 hours after joining the pipes with an adhesive.

Necessary items

- AV cement
- Strap wrench
- Waste cloth

Procedure

- 1) Loosen the Union nut with a strap wrench.
- 2) Remove the Union nut and the End connector.
- 3) Lead the Union nut through the pipe.
- 4) Make sure the hub part of the End connector is clean with waste cloth.
- 5) Apply adhesive evenly to the hub part of the End connector and the pipe spigot.

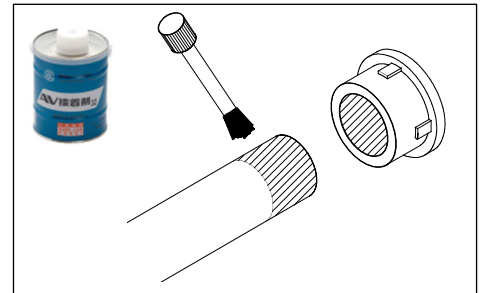

-  - Do not apply more adhesive than necessary. (The valve can be damaged due to solvent cracking.)

Adhesive quantity (guideline)

Nominal size	15mm (1/2")	20mm (3/4")	25mm (1")	32mm (1 1/4")	40mm (1 1/2")	50mm (2")	65mm (2 1/2")	80mm (3")	100mm (4")
Quantity (g) [oz]	1.0 [0.035]	1.3 [0.046]	2.0 [0.071]	2.4 [0.085]	3.5 [0.123]	4.8 [0.169]	6.9 [0.243]	9.0 [0.317]	13.0 [0.459]

- 6) After applying adhesive, insert the pipe quickly to the End connector and leave it alone for at least 60 seconds.
- 7) Wipe away overflowing adhesive.
- 8) Make sure that the O-ring (A) is properly mounted to the body.
- 9) Set the End connector directly on the body without allowing the O-ring (A) to come off.
- 10) Tighten Union nut on each valve until hand tight.
- 11) Using a strap wrench tighten Union nuts uniformly on each side approx. 90° - 180° turns, 1/4 to 1/2 turns.

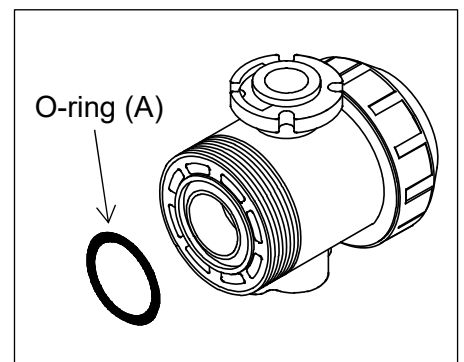

Socket end (PP, PVDF)



- The Union nut of this product is fastened lightly so that it can be loosened easily. Be sure to remove the End connector before carrying out the work. (Failure to do so may cause external leakage.)

Necessary items

- Strap wrench
- Sleeve welder or automatic welding machine
- User's manual for sleeve welder or automatic welding machine

Procedure

- 1) Loosen the Union nut with a strap wrench.
- 2) Remove the Union nut and the End connector.
- 3) Lead the Union nut through the pipe.
- 4) For the next step, refer to the user's manual for the sleeve welder or the automatic welding machine.
- 5) After welding, make sure that the O-ring (A) is properly mounted to the body.
- 6) Set the End connector directly on the body without allowing the O-ring (A) to come off.
- 7) Tighten Union nut on each valve until hand tight.
- 8) Using a strap wrench tighten Union nuts uniformly on each side approx. 90° - 180° turns, 1/4 to 1/2 turns.

Spigot end (PP, PVDF)



- The Union nut of this product is fastened lightly so that it can be loosened easily. Be sure to remove the End connector before carrying out the work. (Failure to do so may cause external leakage.)





Necessary items

- Strap wrench
- Sleeve welder or automatic welding machine
- User's manual for sleeve welder or automatic welding machine

Procedure

- 1) Loosen the Union nut with a strap wrench.
- 2) Remove the Union nut and the End connector.
- 3) Lead the Union nut through the pipe.
- 4) For the next step, refer to the user's manual for the sleeve welder or the automatic welding machine.
- 5) After welding, make sure that the O-ring (A) is properly mounted to the body.
- 6) Set the End connector directly on the body without allowing the O-ring (A) to come off.
- 7) Tighten Union nut on each valve until hand tight.
- 8) Using a strap wrench tighten Union nuts uniformly on each side approx. 90° - 180° turns, 1/4 to 1/2 turns.

13. Support setting procedure

- Caution**   - When screwing in a Metal Insert (Ensat) on the bottom stand with nominal size 15-50mm and supporting, do not concentrate piping stress on Ensat. Refer to the page of "Mounting insert-metal and base" for the screwing in a Ensat.
- Caution**   - When installing a pipe support by means of a U-type clamp or something similar, take care not to over-tighten. (Excessive force may damage the pipe.)

Necessary items

- Spanner wrench
- U-type clamp (with bolt)
- Rubber sheet

Level plumber

< Using metal insert (Ensat) & U-type clamp >

- 1) Fix the installation jig (under the valve) and stand with bolts. (Refer to page 28)
- 2) Spread the rubber sheet on the pipe and secure pipe with U-type clamp.

Ensat screw size

Nom. Size mm [inch]	15-25 [½-1]	32-50 [1¼-2]	65 [2½]	80-100 [3-4]
screw size	M5	M6	M8	M10

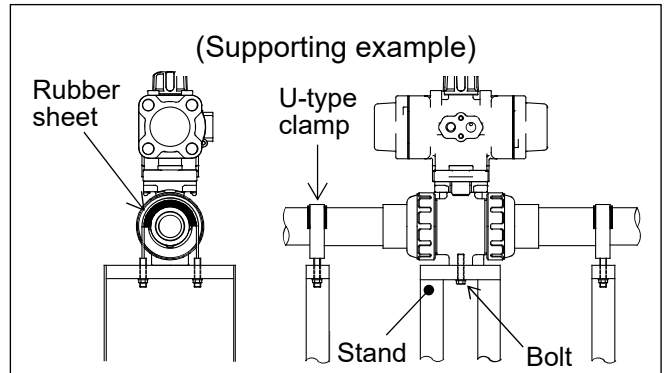

< Do not using metal insert (Ensat), & using U-type clamp >
(Only flanged type)

- 1) Spread the rubber sheet on the pipe and secure pipe with U-type clamp.

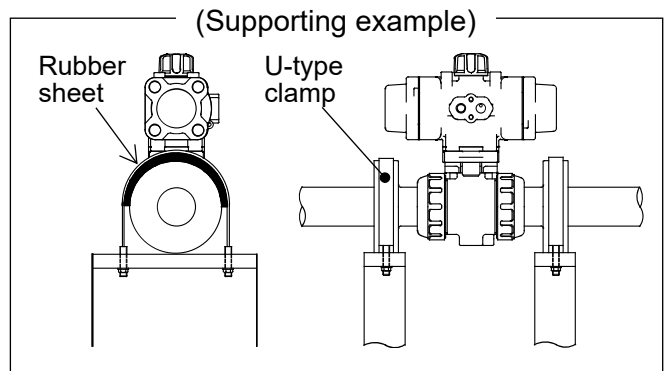

Perpendicular plumber

- 1) Fix the installation jig (under the valve) and stand with bolts. (Refer to page 28)
- 2) Spread the rubber sheet under the actuator, and support with stand.

The conditions and nominal size that do not require actuator support are as follows.



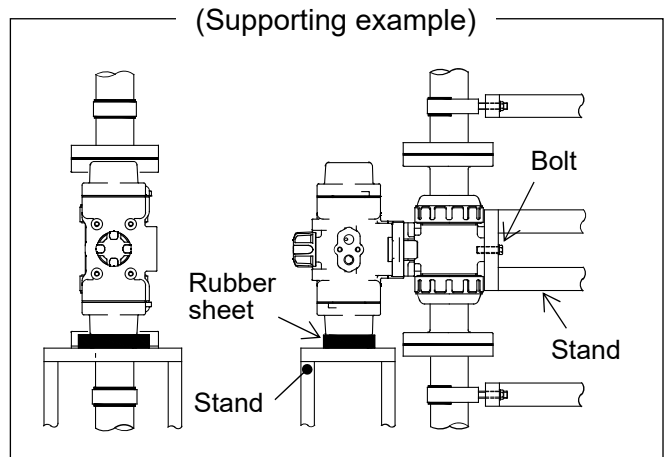

- a) Specifications of actuator
 - Without options
 - With standard speed controller
 - With standard limit switch box

b) Nominal size (mm [inch])



Actuation	15 [½]	20 [¾]	25 [1]	32 [1¼]	40 [1½]	50 [2]	65 [2½]	80 [3]	100 [4]
Double acting	○	○	○	○	○	○	/	/	/
Air to open / Air to close	○	○	○	/	/	/	/	/	/

14. Air piping procedure

- Caution**   - Do not remove a dust-proof cap provided to piping port before piping work starts.
-  - Avoid excessive tightening for joint. (The threaded area can be damaged.)
-  - Check the connection locations, air pipe sizes, and screw types with the approved drawings and other documents for the product. Then lay the air piping.
- Use dehumidified and dust-removed clean operation air. When using highly dry air at a dew point of -40°C or less, please consult us separately.
- If the actuator is used in an environment below 5°C temperature, its operating fluid must be free from the water and moisture contained in it because of possible problems due to the freeze.
-  - Steel pipes must always be of the plated.
- Before installing an actuator in pipeline, flash the inside of pipeline completely.
- When connecting the air piping, be careful not to let foreign matter inside the piping.
- Threaded area of a pipe must be free from the sharp edges and burr.



Necessary items

- Steel pipe or tube for piping
- Joint for steel pipe or tube
- Spanner wrench
- Sealing tape

<For a standard type and an attached speed controller type>

Procedure

- 1) Wind a sealing tape around the external thread of joint, leaving the end (about 3mm) free.
- 2) Screw the joint in the piping female screw of the actuator by hand fully.
- 3) Screw the joint one turn with a spanner wrench.

- Caution**   - Avoid excessive tightening for joint. (The threaded area can be damaged.)

- 4) Mount a steel pipe or a tube.

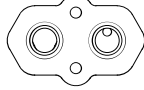
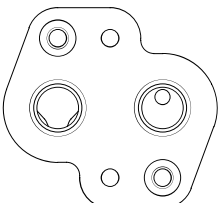
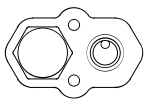
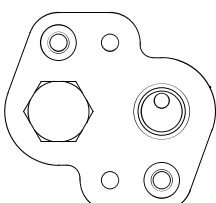
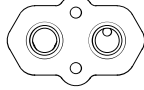
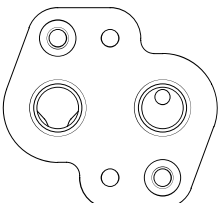
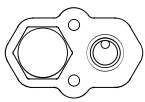
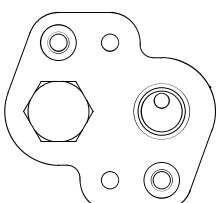
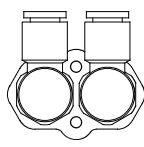
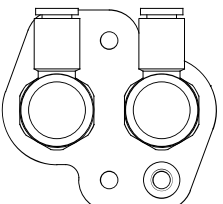
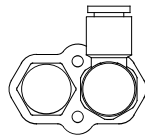
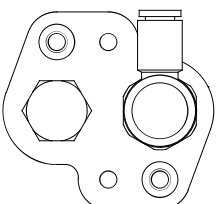
	Double acting		Air to open / Air to close	
	AR032DA10NN AR032DA11NN AR040DA20NN	AR050DA30NN AR063DA40SN AR070DA40SN	AR040NC20SN AR040NO20SN	AR050NC30SN AR050NO30SN AR063NC40SN AR063NO40SN AR070NC40SN AR070NO40SN AR100NC22SN AR100NO22SN
Standard or with speed controller				
Standard type				
With speed controller				

<For a solenoid valve and a filter regulator>

- ! - Set the secondary pressure of the filter regulator to meet the equipment specification. (Failure to do so may cause a malfunction and failure.)
- Discharge drain of the filter regulator regularly.

Necessary items

- Steel pipe or tube for piping
- Joint for steel pipe or tube
- Spanner wrench
- Sealing tape

Procedure

- 1) Wind a sealing tape around the external thread of joint, leaving the end (about 3mm) free.
- 2) Screw the joint in the piping female screw of the actuator by hand fully. (Refer to the lower fig.)
- 3) Screw the joint one turn with a spanner wrench.

⚠ - Avoid excessive tightening for joint. (The threaded area can be damaged.)
 Caution

- 4) Mount a steel pipe or a tube.

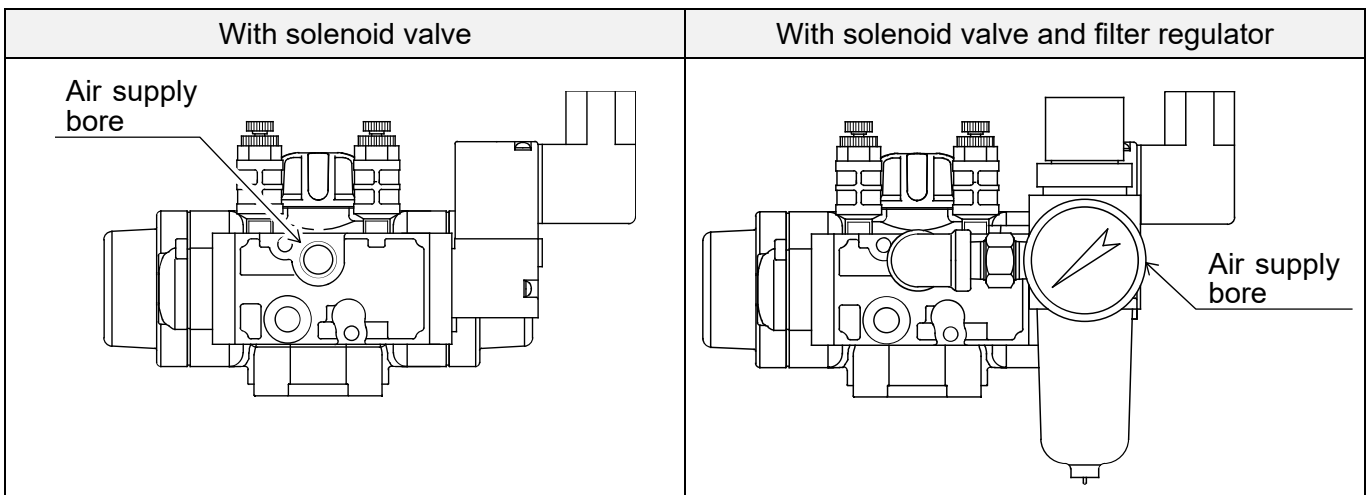

15. Connection of limit switch procedure

< CFC-6301, CFC-6302 >

Warning  - Shut down the power on the equipment before connecting or disconnecting wires. (There are risks of electrical shock depending on machine start suddenly.)

Caution  - Be sure that the terminal cover and body cover are put on during the operation.

 - Firmly tighten the cover. (Rainwater etc. will invade and cause breakdown.)

Necessary items

- Phillips head screw driver
- Flathead screw driver (precision)
- Wire stripper
- Electrician's knife

Procedure

- 1) Loosen the four screws used to attach the limit switch cover with a Phillips head screwdriver and remove cover from the limit switch. (The screw is made so that it will not detach from the cover.)
- 2) Pass the cable through the included connector.
- 3) Use an electrician's knife and wire stripper to strip the cable outer sheath and the insulation from the lead wires.
- 4) Twist the ends of the lead wires together to keep them together.
- 5) Connect terminal screw with a flat head screwdriver according to the internal circuit diagram shown in Specifications of limit switch.

Caution  - Tighten the screws. (If not, electric leaks or shocks may occur.)

- 6) Tighten the above four screws with a Phillips head screwdriver to install cover on the limit switch.
- 7) Tighten the cable by connector.

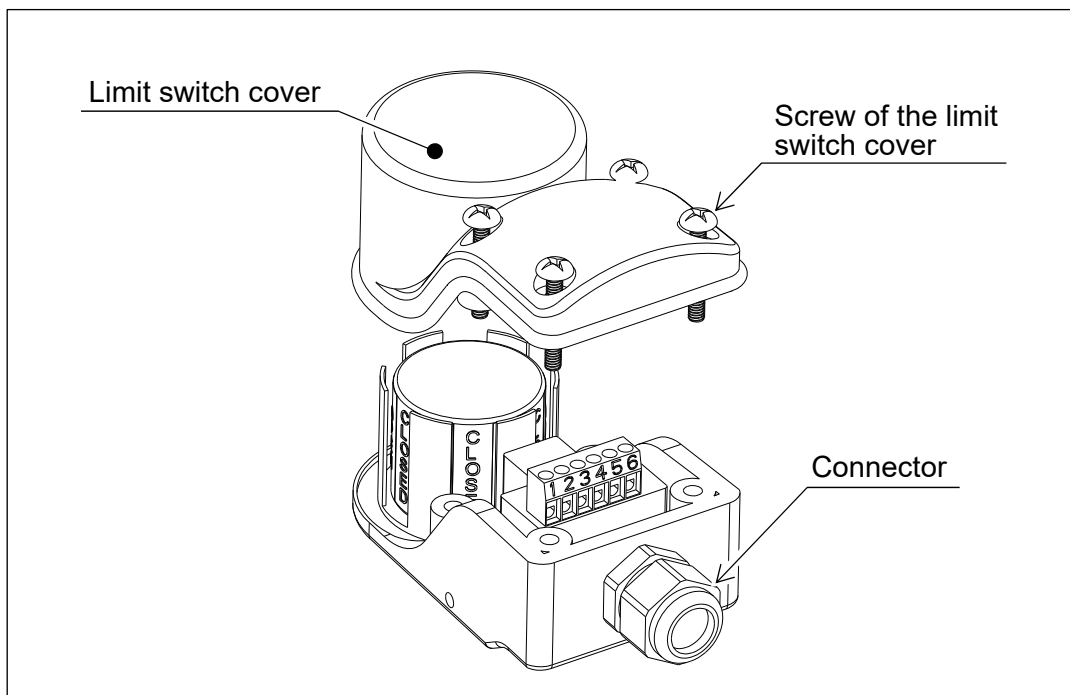

16. Connection of solenoid valve procedure



Caution

- Shut down the power on the equipment before connecting or disconnecting wires. (There are risks of electrical shock depending on the level of operating voltage.)
- Check the solenoid voltage and supply voltage.

Necessary items

- Phillips head screw driver
- Terminal crimping tool
- Wire stripper
- Connector (G1/2)

Procedure

- 1) Loosen the cover setting screw by Phillips head screw driver, and remove the cover.



Caution



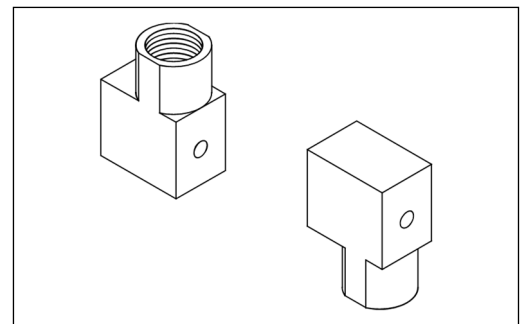
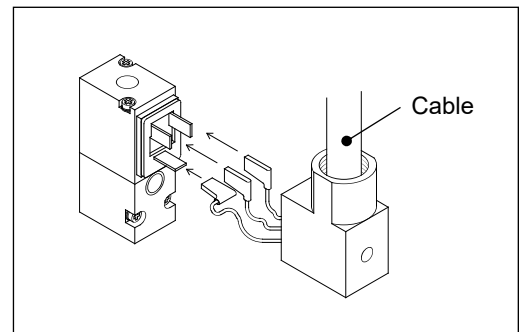
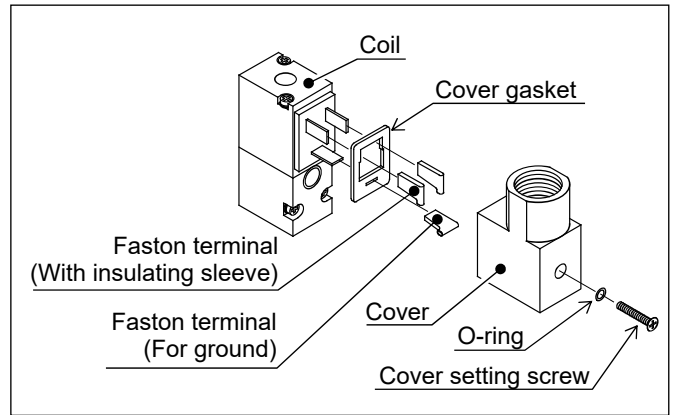

- Don't loss O-ring. (Short circuit or shocks may occur.)

- 2) Remove the Fasten terminal inserted into coil side and the insulating sleeve. (Insulating sleeve isn't attached in Faston terminal.)
- 3) Draw the cable through the connector to the cover.
- 4) Strip cable with a wire stripper.
- 5) Draw the lead wire through the cover.
- 6) Install the Faston terminal on the lead wire with a terminal-crimping tool.
- 7) Insert the Faston terminal into the coil side, and fit the cover. (DC power supply, there is no polarity.)
- 8) Tighten the cover setting screw to fix it. (The cover can be set with the wire extraction opening turned upward or downward.)
- 9) Tighten the cable by connector.



17. Operating procedure

1) Operating procedure by air

-   - Confirm that a wrench for manual operation is not fitted into the output shaft located in the upper part of the actuator.
-   - The AV valves must be used within the specifications specifically applicable to the product. (May not work.)

Procedure

- 1) Supply air to the air supply opening.
- 2) Check that the air supplying side and the indicator position are matching.
- 3) Stop supplying air.

full open and full shut Indication

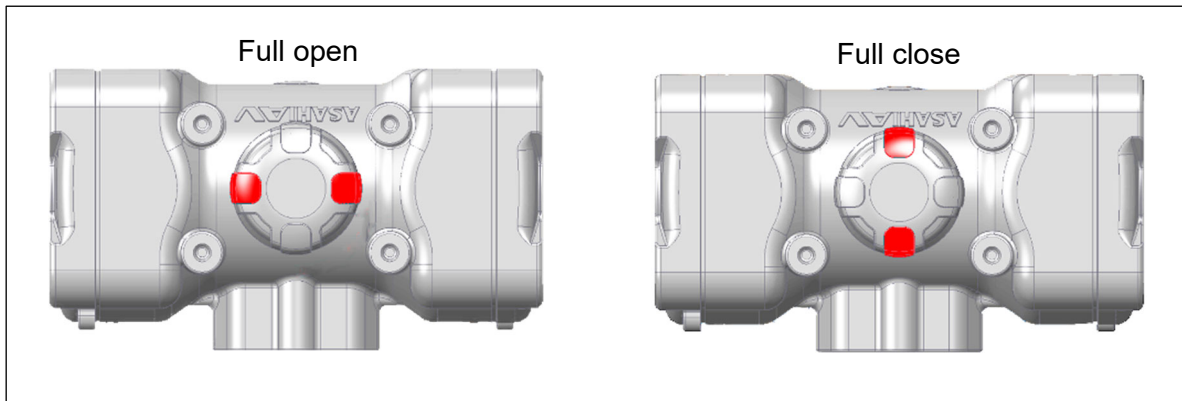

<With solenoid valve>

Procedure

- 1) Supply the air to the solenoid valve.
- 2) Push the button with a finger, and confirm the action mode shown in the under table.
- 3) Apply regular rated voltage to the solenoid valve, and confirm the action mode shown in the following table.
- 4) Turn off the solenoid valve.
- 5) Stop supplying air to the solenoid valve.

Button	Currents	Double acting Air to open	Air to close
Push	On	Open	Close
Not push	Off	Close	Open

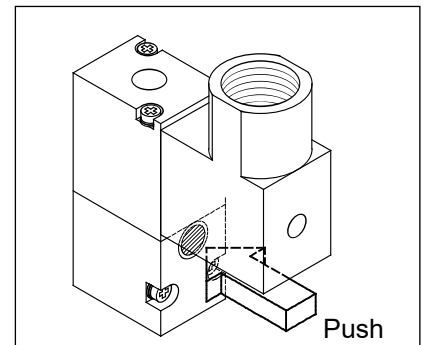

2) Manual operation procedure (double acting only)

 - Don't supply air during manual operation. (When air is supplied during the manual operation, you may be injured.)

 - Do not forcibly rotate the spanner from the fully open or fully closed position. (It breaks down.)

Necessary items



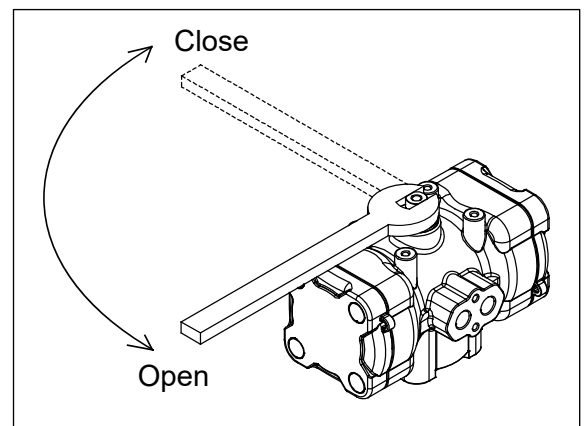
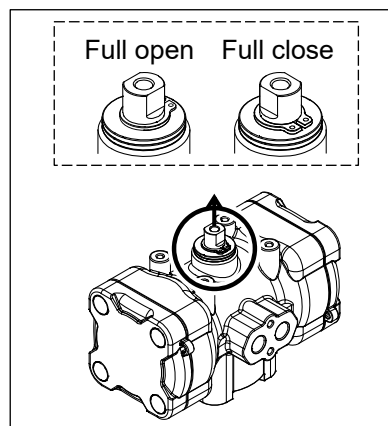
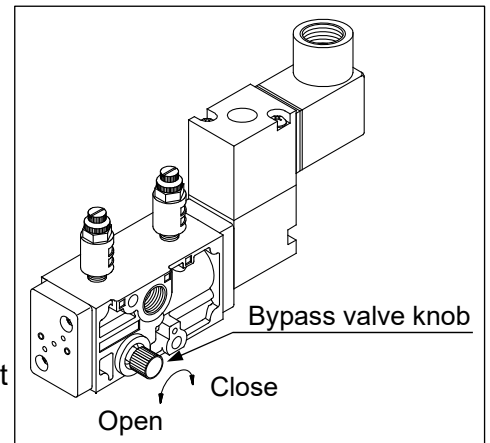
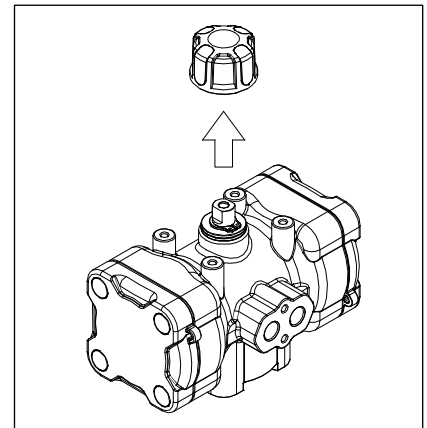

- Spanner wrench

Procedure

- 1) Close main valve for air and turn off the solenoid valve.
- 2) Turn the bypass valve knob counterclockwise, discharge air from the actuator.
- 3) Check the direction (full open or full close) of the indicator before manual operation.
- 4) For the nominal size 15-80mm, pull the indicator attached to the output shaft on the top of the actuator to remove it. For the nominal size 100mm, remove the rubber cap above the indicator, remove the fixing bolt with a hex wrench and then pull the indicator to remove it.
- 5) Fit the wrench to the output shaft on the top of the actuator, and handle the wrench while checking the direction of the output shaft. (When the width across flat of the output shaft is parallel to the piping direction, open state.)
- 6) Return it to the state before the manual operation is performed (full open or full shut), and remove the wrench from the output shaft on the top of the actuator.
- 7) For the nominal size 15-80mm, fit the indicator to the output shaft on the top. For a nominal size of 100 mm, fit the indicator to the upper output shaft and screw in the fixing bolt with a hex wrench to attach the rubber cap.
- 8) Turn the knob of the bypass valve in the clockwise direction to close the bypass valve.
- 9) Open the master valve for operation air to supply air to the solenoid valve.



3) Adjustment of opening / closing speed procedure

- 

 - Be sure to lock the handle (adjustment knob) of the speed controller after adjustment.
- 

 - Avoid excessive tightening of the handle (adjustment knob) of the speed controller. (The speed controller can be damaged.)

< Double acting type >

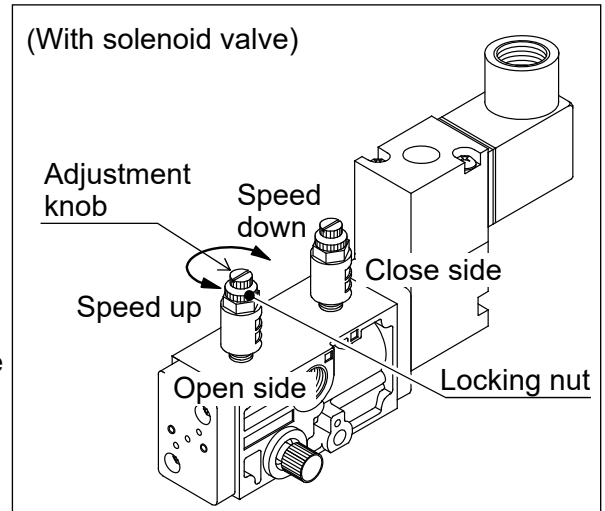
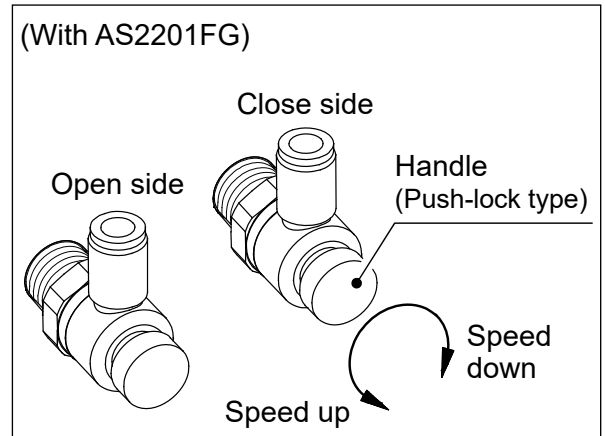
Procedure

- 1) Supply the air to the solenoid valve.
- 2) Open and close unlock the handle (adjustment knob) of both speed controllers.
 - In case of model AS2201FG, pull it up the handle with fingers.
 - In case of solenoid valve, hold the adjustment knob with fingers and loosen the lock nut with a wrench.
- 3) Rotate the handle (adjustment knob) clockwise until it stops turning.
- 4) Open the solenoid valve by energizing it.
- 5) Rotate the handle (adjusting knob) of the open side speed controller little by little counterclockwise.
- 6) Turn off solenoid valve and perform closing operation.
- 7) Rotate the handle (adjusting knob) of the close side speed controller little by little counterclockwise.
- 8) Repeat item 4) to 7) to adjust the opening / closing speed required.
- 9) Open and close lock the handle (adjustment knob) of both speed controllers.
 - In case of model AS2201FG, push the handle with fingers.
 - In case of solenoid valve, hold the adjustment knob with fingers and fasten the lock nut with a wrench.



< Air to open type / Air to shut type >

The actuation type changes the speed-adjustable direction.

actuation type	Opening speed	Closing speed
Air to open	× Not adjustable	○ Adjustable
Air to close	○ Adjustable	× Not adjustable

Procedure

- 1) Supply the air to the solenoid valve.
- 2) Unlock the handle (adjustment knob) of speed controller.
 - In case of model AS2201FG, pull it up the handle with fingers.
 - In case of solenoid valve, hold the adjustment knob with fingers and loosen the lock nut with a wrench.
- 3) Rotate the handle (adjustment knob) clockwise until it stops turning.
- 4) Energize the solenoid valve.
 - Air to open is fully open.
 - Air to shut is fully close.
- 5) After the valve is activated, turn off the solenoid valve.
- 6) Rotate the handle (adjusting knob) of the speed controller little by little counterclockwise.
- 7) Repeat item 4) to 6) to adjust the speed required.
- 8) Lock the handle (adjustment knob) of speed controller.
 - In case of model AS2201FG, push the handle with fingers.
 - In case of solenoid valve, hold the adjustment knob with fingers and fasten the lock nut with a wrench.

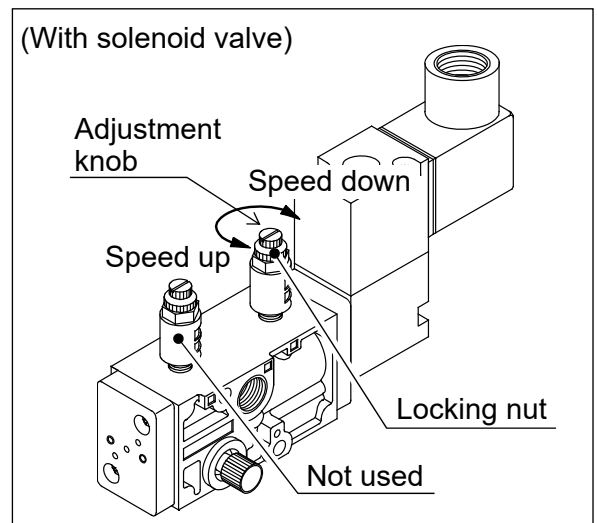
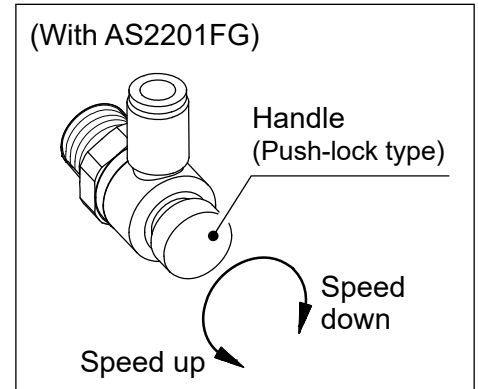

4) Full opening adjustment procedure

Necessary items

- Spanner wrench

Procedure

- 1) Manually rotate the full opening adjustment covers both on the right and left sides in the counterclockwise direction to remove them from the cylinder covers.
- 2) Loosen the nuts both on the right and left sides with a wrench, and rotate the bolts both on the right and left sides in the counterclockwise direction about 5 revolutions with the wrench.
- 3) After supplying air to the opening side of the actuator, rotate the bolts both on the right and left sides in the clockwise direction about a half to a full revolution with the wrench to confirm that the bolts can turn.
- 4) With air still supplied, rotate the bolts both on the right and left sides in the clockwise direction with the wrench until the bolts will not turn any more.

 - Do not rotate the bolts forcibly. (It may cause the actuator to be broken and cause injuries.)

- 5) Release air from the actuator.
- 6) Refer to the following table "Adjustment angle and the number of rotations of the bolt (rough target)" to check the number of rotations of the bolt appropriate for the angle you want to adjust to.
- 7) Rotate the bolt on one side in the clockwise direction with the wrench up to the number of rotations checked with the following table, and rotate the nut with the wrench to secure the bolt. (Leave the bolt on the other side as it is.)
- 8) Supply air to the opening side of the actuator.
- 9) Rotate the bolt on the other side in the clockwise direction with the wrench until it will not turn any more, and rotate the nut with the wrench to secure the bolt.

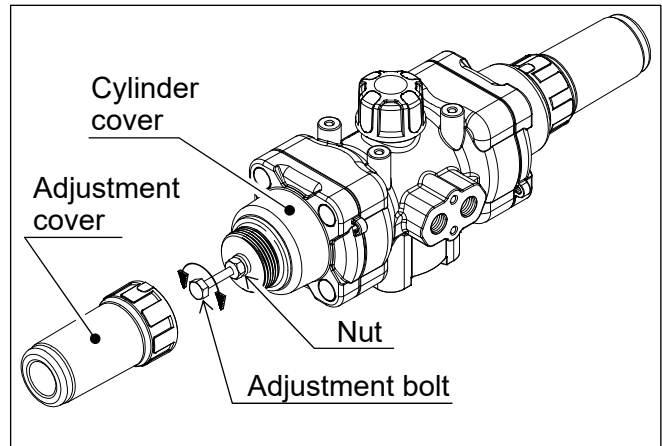

 - Do not rotate the bolts forcibly. (It may cause the actuator to be broken and cause injuries.)

- 10) Release air from the actuator.
- 11) Manually rotate the full opening adjustment covers both on the right and left sides in the clockwise direction to attach to the cylinder covers.



Adjustment angle and the number of rotations of the bolt (rough target)

Unit: Rotation

Model \ Adjustment angle	Adjustment angle									Nut tightening torque N-m {kgf-cm} [lb-inch]
	5°	10°	15°	20°	25°	30°	35°	40°	45°	
AR040□□□□SN	1	2+¼	3+¼	4+¼	5+½	6+½	7+¾	8+¾	9+¾	3.0 {30.6} [26.6]
AR050□□30SN	1	2	3+¼	4+¼	5+¼	6+¼	7+¼	8+½	9+½	5.2 {53.0} [46.0]
AR063□□40SN	1+¼	2+¼	3+¼	4+½	5+½	6+¾	7+¾	9	10	12.5 {127.5} [110.7]
AR070□□40SN	1+½	3	4+½	6	7+½	9	10+½	12	13+½	24.5 {249.9} [216.9]
AR100□□22SN	½	1	1+½	3	3+½	5	5+½	7	7+½	106 {1080.9} [938.2]

18. Mounting insert-metal and base (panel)

< Attach Inserted metal to the bottom stand >

  - When screwing in a Metal Insert (Ensat), install it vertically.
 Caution - Refer to the User's Manual for Metal Insert (Ensat) by the maker.

Procedure

Refer to the user's manual for the Metal Insert (Ensat).

Bottom stand dimension Unit: mm (inch)

Nominal size	S ₁	S ₂	S ₃
15mm (1/2")	19 (0.75)	7.3 (0.29)	11 (0.43)
20mm (3/4")	19 (0.75)	7.3 (0.29)	11 (0.43)
25mm (1")	19 (0.75)	7.3 (0.29)	11 (0.43)
32mm (1 1/4")	30 (1.18)	9 (0.35)	15 (0.59)
40mm (1 1/2")	30 (1.18)	9 (0.35)	15 (0.59)
50mm (2")	30 (1.18)	9 (0.35)	15 (0.59)
65mm (2 1/2")	48 (1.89)	9 (0.35)	6 (0.24)
80mm (3")	55 (2.17)	11 (0.43)	7 (0.28)
100mm (4")	65 (2.56)	11 (0.43)	8 (0.31)

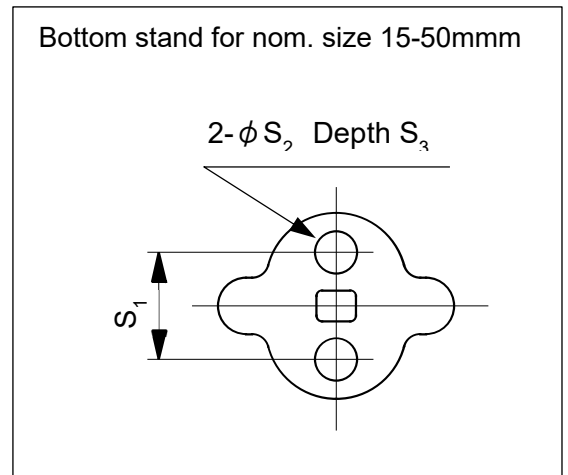

Applicable Ensats (Reference) *Only 50mm or less

Nominal size	Screw size	Length mm (inch)	Material
15mm (1/2")	M5	10 (0.39)	Brass
20mm (3/4")	M5	10 (0.39)	
25mm (1")	M5	10 (0.39)	
32mm (1 1/4")	M6	14 (0.55)	
40mm (1 1/2")	M6	14 (0.55)	
50mm (2")	M6	14 (0.55)	

Maker: K.K.V. Corporation

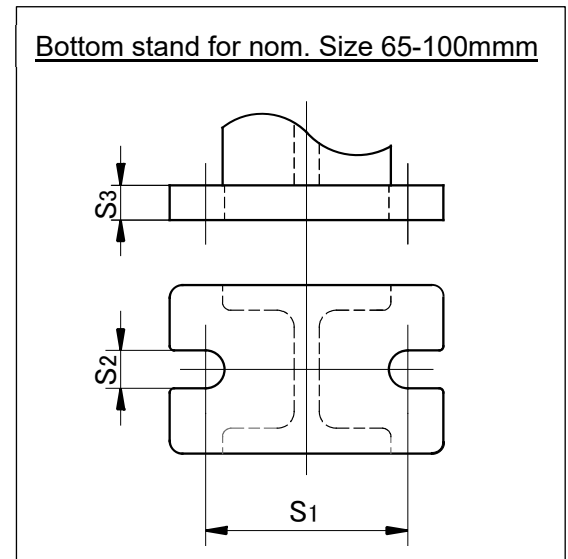

< Fixation of bottom stand with panel >

Nominal side 15-50mm (1/2"-2")

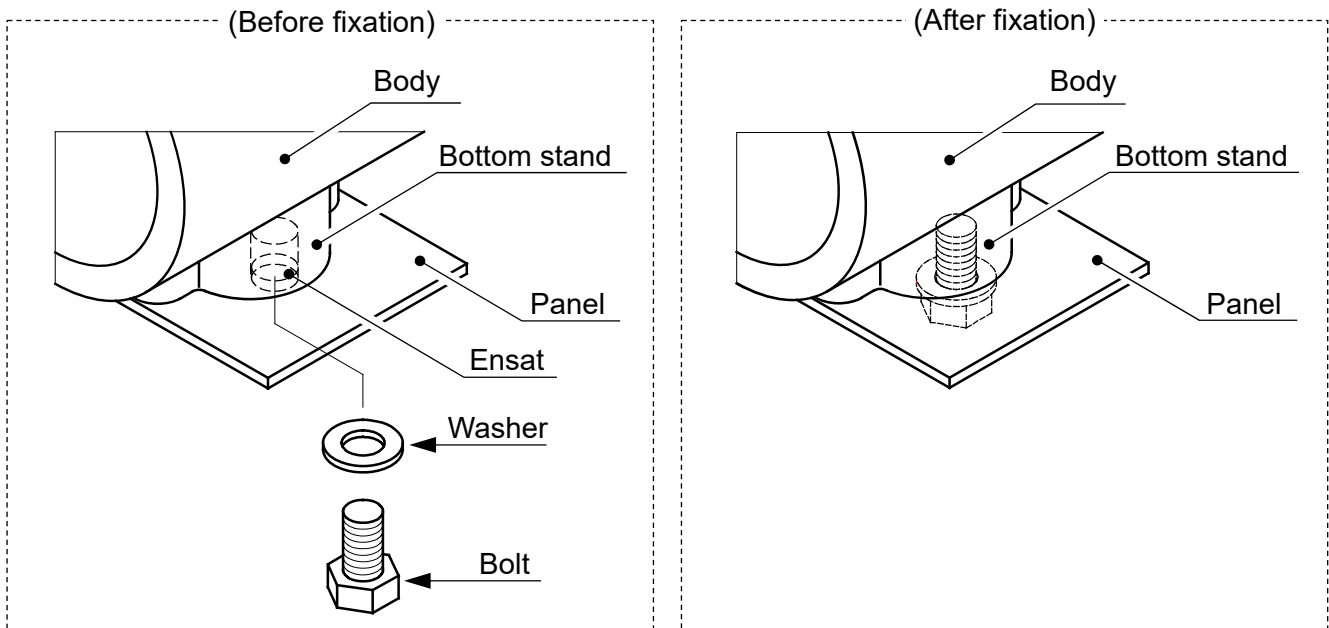

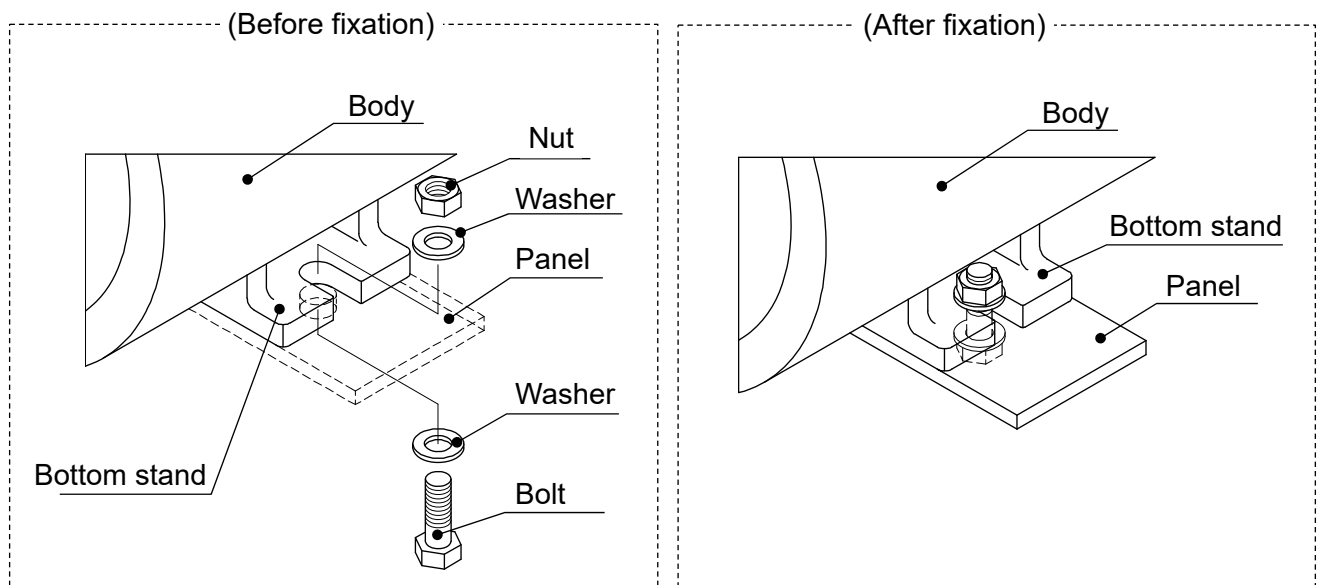

Nominal size 65-100mm (2 1/2"-4")



19. Actuator removal procedure

< Nominal size 15-50mm(1/2"-2") >

- Caution**  - When removing the actuator, be sure to use the "Base plate removing jig". (Failure to do so may cause damage to the Base plate.)
- Caution**  - When removing the base plate from the valve, avoid applying excessive force to a base plate removing jig to force the claw to open. (It may cause the claw to be broken.)
- Caution**  - Avoid excessive repetition of attaching and removing the base plate. (It may cause the claws of the base plate to have fatigue fracture.)
- A single-action type has a metal joint (shaft adapter) between the valve and actuator. Be careful of the shaft adapter's jumping out and falling when removing the base plate from the valve.
- Be careful not to apply excessive load to the pipe and valve when attaching and removing the base plate.

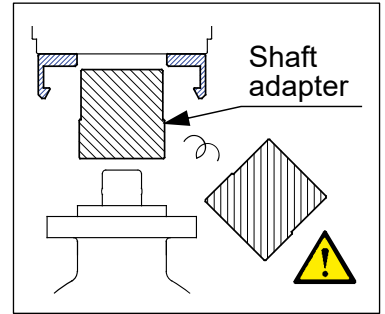
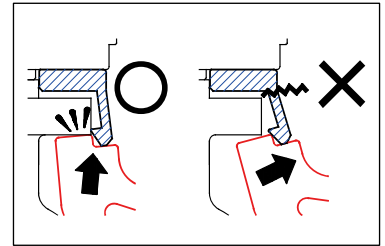

Necessary items

- Base plate removing jig (Optional items)



< Removal >

Procedure

- 1) Completely eliminate pressure in the pipe.
- 2) Close the master valve for operation air, and release air from the actuator.
- 3) Remove the air pipe.
- 4) Put the tip of the base plate removing jig at the center of the claw on one side of the base plate. (Refer to Fig. 19-1.)
- 5) Move the removing jig in a way that it pushes the claw of the base plate upward with the side of the valve as a fulcrum to release the hooking with the main body of the valve. (Refer to Fig. 19-2.)
- 6) For the other claw, perform the steps 4) to 5) to release the hooking with the main body of the valve.
- 7) When the hooking of the both claws is released, lift the actuator vertically to disconnect from the valve. (Refer to Fig. 19-3.)

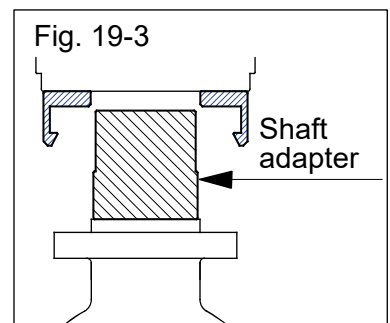
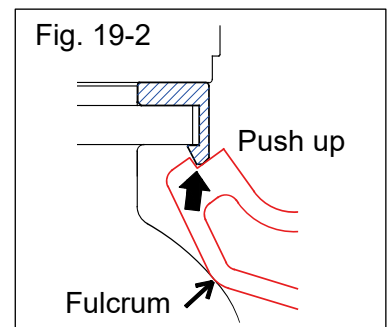
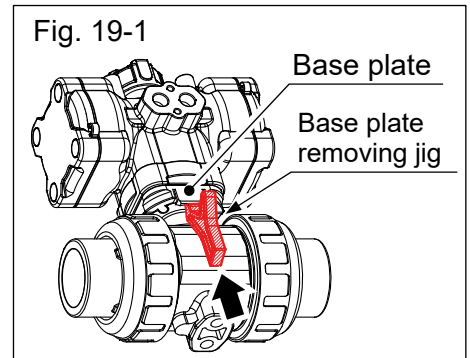





< Attachment >

Procedure

- 1) Confirm that the opening display of the actuator and the directions of the valve stem and shaft adapter are correct.
- 2) Check the fitting position of the top flange of the valve and the base plate.
- 3) Push the base plate onto the valve until its claws firmly catch the top flange while checking visually.

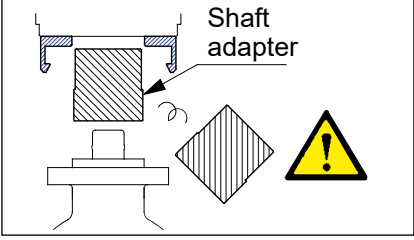
< Nominal size: 65 ~ 100mm (2½" ~ 4") >

 Caution		• A nominal size 100mm (4") has a metal joint (shaft adapter) between the valve and actuator. Be careful of the shaft adapter's jumping out and fall when removing the base plate from the valve.	
 Caution		• The actuator is heavy, so be careful not to fall it.	

Necessary items

- Hex wrench (For M6, and Hexagon width is 5mm)

<Removal>

Procedure

- 1) Completely eliminate pressure in the pipe.
- 2) Double acting and air to open will left opening, air to close type will right opening.
- 3) Close the master valve for operation air, and release air from the actuator.
- 4) Remove the air pipe.
- 5) Remove the rubber cap on the cover plate. (Refer to Fig. 19-4.)
- 6) Loosen the bolt that secures the cover plate with a hex wrench until the nut is no longer hooked.
- 7) Grasp the cover plate with your hand, and slide it back and forth to remove it. (Refer to Fig. 19-5)
- 8) Lift the actuator to remove it from the valve. (Refer to Fig. 19-6)

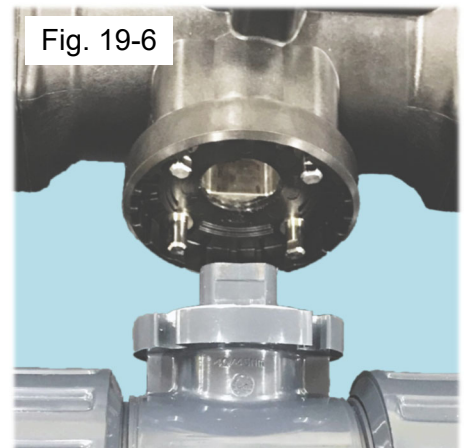
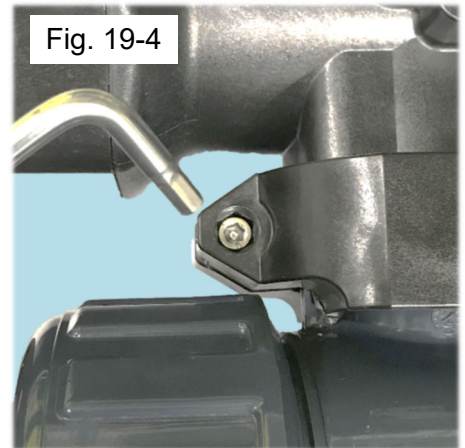

<Attachment>

Procedure

- 1) Confirm that the opening display of the actuator and the directions of the opening indication label at the top of the valve stem and shaft adapter are correct.
- 2) Check the fitting position of the top flange of the valve and the base plate.
- 3) Push in while visually checking until the base plate fits into the top flange of the valve.
- 4) Attach the cover plate to the top flange of the valve, and tighten the bolts with a hex wrench to secure the cover plate. (Recommended tightening torque: 5.2N-m)
- 5) Attach the rubber cap on the cover plate.

20. Method of adjusting face pressure between ball and seat

- Warning** - If you do work with the piping installed, drain the piping of all its fluid. Some fluid will remain in the valve. Therefore wear protective goggles and protective gloves. (You may otherwise get injured.)
- Caution** - Take care not to over-tighten the Union nut. (The valve can be damaged.)
- Caution** - Do not use the pipe wrench. (The valve can be damaged.)

Necessary items

- Strap wrench
- Safety goggles
- Protective gloves
- Handle (For manual valve)
- Base plate removing jig (Optional items)

< Adjust surface pressure >

Procedure

- 1) Completely eliminate pressure in the pipe, and completely discharge fluid from line.
- 2) Remove the actuator according to Procedure 2) to 7) in the "Actuator removal procedure".
- 3) In case of air to open type and air to shut, remove the shaft adapter.
- 4) Attach the handle to the stem, and turn the handle to close the valve completely.
- 5) Loosen the right Union nut and the left one with a strap wrench.
- 6) Remove the body part from piping system.
- 7) Make the valve half-open with a handle for manual valve, and remove the remaining fluid in the valve. Then remove the handle with the valve fully closed.
- 8) Remove the O-ring (A) at the Carrier.
- 9) Engage the upper convex part of the handle with the concave part of the union.
- 10) Rotate the Carrier to adjust the surface pressure.

	Type 21	Type 21 α
Loosen	Counter clockwise	Clockwise
Tighten	Clockwise	Counter clockwise

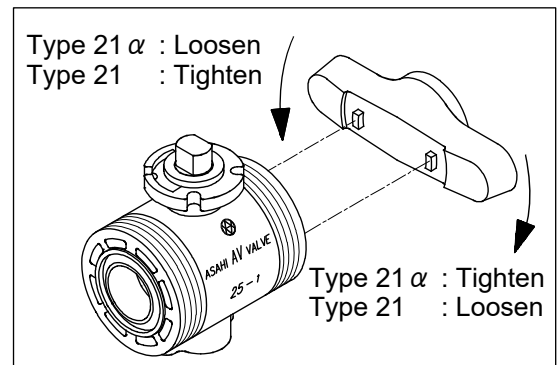
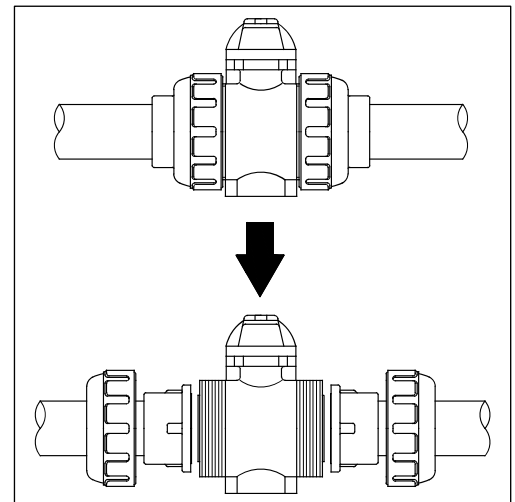





- 11) Attach the handle for manual valve to the stem, and confirm that manual operation can be performed smoothly.

< Assembly >

- 1) Perform in reverse order from step 8) of "Adjust surface pressure".
 - * When attaching the actuator to the valve, confirm that the direction of the opening display of the actuator and the direction of the stem are correct. Then push the actuator into the top flange of the valve to attach.

21. Disassembling method for replacing parts

- Warning**  - If you do work with the piping installed, drain the piping of all its fluid. Some fluid will remain in the valve. Therefore wear protective goggles and protective gloves. (You may otherwise get injured.)
- Caution**   - Take care not to over-tighten the Union nut. (The valve can be damaged.)
- Caution**   - Do not use the pipe wrench. (The valve can be damaged.)

Necessary items

- Strap wrench
- Safety goggles
- Protective gloves
- Handle (For manual valve)
- Base plate removing jig (Optional items)

<Disassembly>

Procedure

- 1) Completely eliminate pressure in the pipe, and completely discharge fluid from line.
- 2) Remove the actuator according to Procedure 2) to 7) in the "Actuator removal procedure".
- 3) In case of air to open type and air to shut, remove the shaft adapter.
- 4) Attach the handle to the stem, and turn the handle to close the valve completely.
- 5) Loosen the right Union nut and the left one with a strap wrench.
- 6) Remove the body part from piping system.
- 7) Make the valve half-open with a handle for manual valve, and remove the remaining fluid in the valve. Then remove the handle with the valve fully closed.
- 8) Remove the O-ring(A) at the Carrier.
- 9) Engage the upper convex part of the handle with the concave part of the union.
- 10) Turn the handle and remove the Carrier.

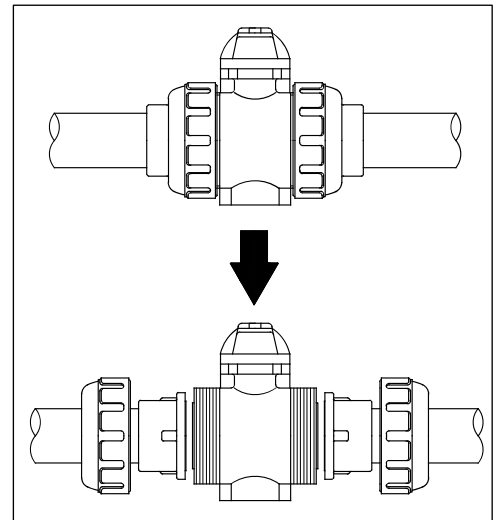

	Type 21	Type 21
Loosen	Counter clockwise	Counter clockwise
Tighten	Clockwise	Clockwise

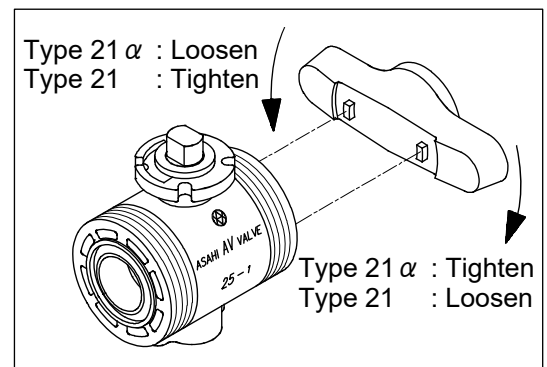

- 11) Remove the seat, O-ring (B), and O-ring (C) carefully from the Carrier without damaging it.
- 12) Push out the ball by hand.
- 13) Put out the stem from the top flange side to the body side.
- 14) Remove the seat and O-ring (C) carefully from the body without damaging it.
- 15) Remove the O-ring (D) and O-ring (E) carefully from the stem without damaging it.

Procedure

1) Assemble it in the reverse order to the procedure of "Disassembly" from Step 15.



* When attaching a seat, confirm the front and rear sides of the seat.

When attaching the actuator to the valve, confirm that the direction of the opening display of the actuator and the direction of the stem are correct. Then push the actuator into the top flange of the valve to attach.

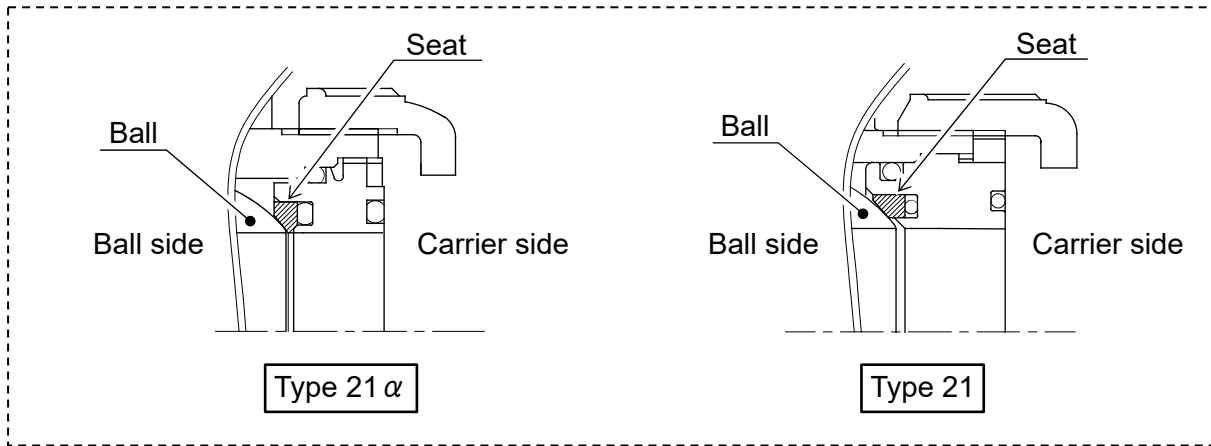
* Dent side = Contact with the ball



22. Inspection items

  - Perform periodic maintenance. (Leakage may develop due to temperature changes or over periods of prolonged storage, rest or operation.)

Portion to be inspected	Inspection item
Actuator	<ul style="list-style-type: none"> - Existence of rust and corrosion on the appearance. - Tightening condition of respective threaded portions. (Loose or not) - Existence of abnormality in opening and closing operating sounds. - Smooth opening and closing operation <ul style="list-style-type: none"> * Even if the valve is operated less frequently, confirm that it opens and closes smoothly at least once per 30 days. * It is unnecessary to supply oil to this actuator.
Base plate	<ul style="list-style-type: none"> - Mating condition of the base plate or cover plate.(Loose or not)
Valve	<ul style="list-style-type: none"> - Existence of scratches, cracks, deformation, and discoloring. - Existence of leakage from the valve to the outside. - Existence of leakage when the fully closed.

23. Troubleshooting

Problem	Cause	Treatment
The spanner does not turn (or cannot rotate) during manual operation at double acting type.	Already fully open or fully shut.	Turn the spanner in the opposite direction.
	Air is supplied to the actuator.	Close the master valve for operation air, and open the bypass valve.
	Foreign matter is in the valve.	Disassemble valve to remove foreign matter.(Refer to pages 33)
	Valve torque is increasing due to piping stress.	Remove the piping stress.
	The torque is increased by the influence (temperature, components, pressure) of fluid on the valve.	Check the service condition. (Refer to pages 7 and 8)
The valve does not operate by air operations.	The power source of the control panel is Turned off.	Turn on the power source.
	The solenoid valve is disconnected.	Check the connection again. (Refer to page 10 and 22)
	Air is not supplied to the solenoid valve.	Supply air to solenoid valve.
	The supply voltage to the solenoid valve is wrong.	Check voltage with a tester and set specified voltage.
	The voltage to the solenoid valve is low.	
	The bypass valve opens.	Close bypass valve by turning the bypass valve knob in a clockwise direction.
	The speed controller's knob is fully turned in a clockwise direction.	Turn speed controller's knob in a counterclockwise direction. (Refer to pages 25)
	Foreign matter is in the valve.	Disassemble valve to remove foreign matter. (Refer to pages 33)
	Valve torque is increasing due to piping stress.	Remove the piping stress.
	The torque is increased by the influence (temperature, components, pressure) of fluid on the valve.	Check the service condition. (Refer to pages 7 and 8)
Fluid leaks from the valve even when the valve is closed fully.	The Carrier is loosened.	Adjust the face pressure between the ball and the seat.(Refer to pages 33)
	The seat is worn.	Replace the seat with a new one.(Refer to pages 33)
	The seat and ball are scratched.	Replace scratched parts with new one. (Refer to pages 33)
	Foreign matter is in the valve.	Discharge the foreign matter from the valve by opening and closing the valve several times.
Fluid leaks from the valve.	The Union nut is loosened.	Tighten the Union nut.
	The O-ring is scratched or worn.	Replace the O ring with a new one. (Refer to pages 33)
	The O-ring is projected from the groove.	
	The sliding face or the fixed face of the O-ring is scratched or worn.	Replace scratched parts with new one. (Refer to pages 33)
The actuator operates, but the valve does not open or close.	The stem or the shaft adapter is broken.	Replace scratched parts with new one. (Refer to pages 33)
	The engagement between the stem and the ball is broken.	

24. How to inquire about defects or replacement

- ! - If you fail to remedy a defect even if you take measures against the defect or take corrective actions, or when a part needs to be replaced, check the information on the labels attached to the actuator and valve and contact the nearest sales office.

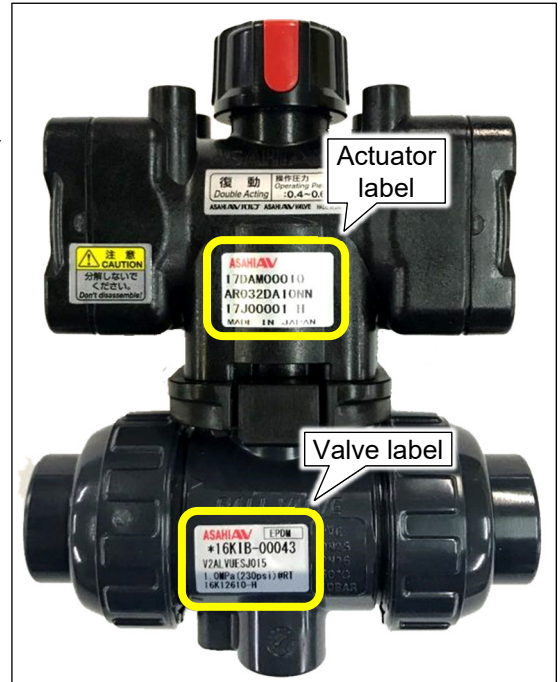

25. Handling of residual and waste materials

- Warning ! - Make sure to consult a waste treatment dealer for recommendations on the proper disposal of plastic valves. (Poisonous gas is generated when the valve is burned improperly.)

Ball Valve Type21·21 α Pneumatic Actuated Type AR
15-100mm (1/2" - 4")

ASAHI YUKIZAI CORPORATION



The product names, logos, and other trademarks mentioned in this instruction manual are all registered trademarks of ASAHI YUKIZAI CORPORATION.

These trademarks are the intellectual property of ASAHI YUKIZAI CORPORATION and may not be used without permission.

Nothing in this manual grants a license to use the trademarks, either expressly or implicitly.

For further details regarding registered trademarks, please contact ASAHI YUKIZAI CORPORATION.

Distributor

<https://www.asahi-yukizai.co.jp/en/>