

**Butterfly valve type 58  
Pneumatic Actuated  
Type FL  
700mm (28") ~900mm (36")**

**User's Manual**



Thank you very much for choosing our product.

This instruction manual is for your safety to use our product.

This manual contains important information. Be sure to read this manual before handling the product.

After reading this manual, the user can refer to it at any time.

Please be sure to keep it.

**ASAHI YUKIZAI CORPORATION**

## -SAFETY PRECAUTIONS-



This instruction manual is written on the assumption that the person who handles our products has a basic knowledge of our products, electrical equipment, machinery, control, etc., and it contains technical terms depending on the handling contents.

Please read this manual carefully and fully understand the contents and observe the safety precautions for proper use.



In this manual, the warning, caution, prohibition, and enforcement are categorized together with the symbol to inform the situation and scale of human injury or property damage.

Failure to observe this precaution may result in unexpected failure or damage. Be sure to observe this precaution.

### <WARNING/CAUTION indications>

 <b>WARNING</b>	Indicates a potentially hazardous situation which, <b>if not avoided, could result in death or serious injury.</b>
 <b>CAUTION</b>	Indicates a potentially hazardous situation which, <b>if not avoided, may result in minor or moderate injury or property damage.</b>

### <Prohibited/Forced display>

 <b>Prohibition</b>	In the handling of the product, <b>it is prohibited to do it in "Do not do it".</b>
 <b>Forcing</b>	In the handling of the product, <b>it is forced by "contents to be carried out without fail".</b>

## Table of contents

<b>1. Our product warranty coverage</b> .....	<b>4</b>
Applicable to .....	4
Warranty Period.....	4
Guaranteed range.....	4
Disclaimer.....	4
<b>2. Safety Instructions</b> .....	<b>5</b>
Unpacking, Transportation and Storage.....	5
Product Handling.....	6
<b>3. Name of each part</b> .....	<b>8</b>
<b>4. Product Specifications</b> .....	<b>8</b>
Product model code list.....	8
Relationship between maximum allowable pressure and temperature .....	9
Actuator.....	9
Standard option .....	9
Solenoid Valve Specification .....	10
Filter regulator specifications .....	11
Speed controller specifications.....	11
Limit switch box specifications.....	12
<b>5. Piping method</b> .....	<b>13</b>
Wafer shape .....	13
Product support.....	18
<b>6. Air piping method</b> .....	<b>19</b>
<b>7. How to Connect Options</b> .....	<b>21</b>
Limit switch.....	21
Solenoid valve.....	22
<b>8. Manual operation</b> .....	<b>23</b>
Manual operation .....	23
<b>9. Air Operation</b> .....	<b>25</b>
<b>10. How to adjust the stopper</b> .....	<b>26</b>
<b>11. How to adjust open/close speed</b> .....	<b>27</b>
<b>12. Inspection item</b> .....	<b>28</b>
Daily inspection .....	28
Periodic inspection.....	29
<b>13. Troubleshooting</b> .....	<b>31</b>
<b>14. How to inquire about defects or replacement</b> .....	<b>34</b>
<b>Contact</b> .....	<b>35</b>

## 1. Our product warranty coverage

Unless otherwise stated in the Contract or Specifications, etc., the warranty for the piping material products (hereinafter referred to as "applicable products") such as valves manufactured or sold by us is as follows.

### Applicable to

This warranty applies only when the product is used in Japan. If you intend to use the product overseas, please contact us.

### Warranty Period

The warranty period is one year after delivery.

### Guaranteed range

In the event of failure or malfunction due to our responsibility during the above warranty period, we will replace or repair the product with a substitute free of charge.

Provided, however, that even within the warranty period, the warranty shall not apply to any of the following cases (charged service).



- ▶ When the storage, operating conditions, precautions, etc. described in the specifications, instruction manual, etc. are not adhered to in the construction, installation, handling, maintenance, etc.
- ▶ Defects, such as the design of the customer's equipment or software, caused by other than the target product.
- ▶ The fault is due to modification or secondary processing of the product by something other than us.
- ▶ In the case of a failure which can be deemed to have been avoided if the periodic inspection described in the instruction manual, etc. or the maintenance or replacement of consumable parts has been performed normally.
- ▶ The component is used for purposes other than the product's intended use.
- ▶ Failure or malfunction due to causes that could not be foreseen by our level of science and technology at the time of shipment.
- ▶ The fault is due to an external factor that is not our responsibility, such as natural disaster or disaster.



### Disclaimer

- ▶ The warranty will not cover secondary damage (damage to equipment, loss of opportunity, loss of profit, etc.) or any other damage caused by the failure of our product.
- ▶ Although we strive to improve the quality and reliability of our products, we do not guarantee their integrity. Especially when using this product for equipment that may infringe human life, body or property, take appropriate safety design measures, etc., with full consideration of problems that may normally occur. We assume no responsibility for such use if we have not obtained our consent in advance in writing of specifications, etc.
- ▶ Please observe the product specifications and precautions when using our products. We shall not assume any responsibility for any damage to the customer caused by the customer's negligence. However, this does not apply to damage caused by a defect in our product.



## 2. Safety Instructions



### Unpacking, Transportation and Storage

 <b>WARNING</b>	
 <b>Prohibition</b>	<p><b>Serious injury can result.</b></p> <ul style="list-style-type: none"> <li>▶ When hanging or slinging a valve, pay sufficient attention to safety, and do not enter under the load.</li> </ul>



 <b>CAUTION</b>	
 <b>Prohibition</b>	<p><b>The valve can be damaged, damaged, or leak.</b></p> <ul style="list-style-type: none"> <li>▶ Do not subject the product to impact by throwing, dropping or hitting.</li> <li>▶ Do not scratch or pierce the product with a sharp object such as a knife or hand hook.</li> <li>▶ Avoid contact with coal tar, creosote (a wood preservative), white pesticides, insecticides, paints, etc.</li> </ul>
 <b>Forcing</b>	<p><b>The valve can be damaged, damaged, or leak.</b></p> <ul style="list-style-type: none"> <li>▶ Store the product indoors (at room temperature) in direct sunlight, with the product packed until just before piping. Also, avoid storing the product in places of high temperature.</li> <li>▶ After unpacking, make sure that the product is correct and that it meets the specifications.</li> </ul>

**Product Handling**

 <b>WARNING</b>	
 <b>Prohibition</b>	<p><b>Serious injury can result.</b></p> <ul style="list-style-type: none"> <li>▶ Do not disassemble the actuator.</li> <li>▶ Do not touch moving parts during operation with hands, feet or tools.</li> </ul>
 <b>Forcing</b>	<p><b>There is a danger of injury.</b></p> <ul style="list-style-type: none"> <li>▶ If positive pressure gas is used for our resin piping material, a dangerous condition may occur due to the repulsive force peculiar to compressible fluids even if the pressure is the same as the water pressure. Therefore, be sure to take safety measures for the surrounding area, such as covering the piping with protective materials. If you have any questions, please contact us separately.</li> <li>▶ When conducting a pipe leak test after completion of piping construction, be sure to check with water pressure. Contact us in advance if you are unavoidable to test with a gas.</li> </ul>

 <b>CAUTION</b>	
 <b>Prohibition</b>	<p><b>The valve can be damaged, damaged, or leak.</b></p> <ul style="list-style-type: none"> <li>▶ Do not step on the valve or place heavy objects on it.</li> <li>▶ Keep away from fire and hot objects.</li> <li>▶ Do not use the product in places where it may be submerged.</li> <li>▶ Do not subject the valve to large vibrations.</li> </ul>
 <b>Forcing</b>	<p><b>There is a danger of injury.</b></p> <ul style="list-style-type: none"> <li>▶ When performing manual operation, make sure that the operation air in the actuator is completely exhausted.</li> <li>▶ Secure sufficient space for maintenance and inspection when piping.</li> </ul>

Handling of products (continued)

 <b>WARNING</b>	
 <b>Forcing</b>	<p><b>Doing so may cause the actuator to stop moving.</b></p> <ul style="list-style-type: none"> <li>▶ Prevent foreign matter, water droplets, oil, etc. from entering the actuator through the air piping or air intake or exhaust holes. Be especially careful in areas where there is a possibility of snow accumulation, as snow melting water may enter.</li> <li>▶ When installing the product in a place where the ambient temperature may be 5° C or less, remove moisture from the operation air to prevent freezing.</li> <li>▶ When installing the product in a location with a low-temperature environment, provide a cover to cover the whole area to prevent the actuator from freezing, and periodically check the operation status.</li> <li>▶ Use clean, dehumidified and dedusted operating air. However, consult with CKD when using high-dry air with a dew point of -40° C or less.</li> </ul> <p><b>The valve can be damaged, damaged, or leak.</b></p> <ul style="list-style-type: none"> <li>▶ Confirm that the operation air is within the allowable range before use.</li> <li>▶ Pay attention to the atmosphere where the valve is installed. Avoid locations where the product is exposed to sea breezes, corrosive gases, chemical liquids, sea water, steam, etc.</li> <li>▶ Keep the pressure and temperature of the fluid and the ambient temperature within the allowable range.</li> <li>▶ Use a valve of suitable material for the operating conditions. (Depending on the type of chemical liquid, the parts may be damaged. Contact us in advance for details.)</li> <li>▶ Use fluids containing crystalline material under conditions that do not recrystallize.</li> <li>▶ Avoid installing the valve in places where it is constantly exposed to splashes of water or dust, direct sunlight, or in places with volatile gases or poor atmospheres, or protect the valve with a cover or the like to cover the entire area.</li> <li>▶ Perform maintenance periodically. Pay particular attention to temperature changes and aging during long-term storage or shutdown or use.</li> <li>▶ When installing a valve, provide an appropriate valve support so that excessive force is not applied to the valve and piping.</li> <li>▶ Always use the product within the range of the indicated product specifications.</li> </ul>

### 3. Name of each part

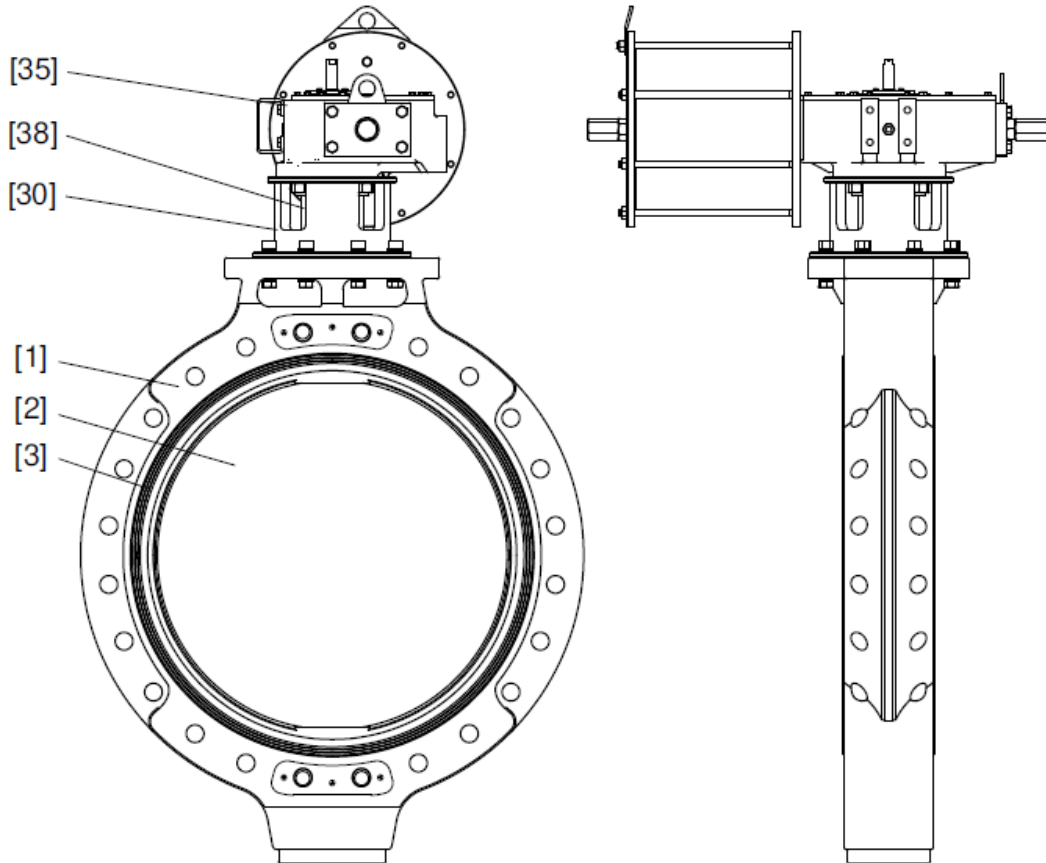

[1]	Body	[35]	Actuator
[2]	Disc	[30]	Stand
[3]	Seat	[38]	Joint

### 4. Product Specifications

#### Product model code list

Actuation	Type	Operating system	Body material	Seal material	Connection	Standard	Size	High purity series	Disc PVDF
<b>A</b>	<b>58</b>	<b>FF</b>	<b>D</b>	<b>*</b>	<b>W</b>	<b>*</b>	<b>***</b>	<b>0</b>	<b>0Q</b>
A Automatic	58 Type 58	FF Pneumatic Type FL (DA)	D PDCPD	E EPDM V FKM	W Wafer	1 JIS 10K D DIN A ANSI	700 700mm (28") 800 800mm (32") 900 900mm (36")	0 Non	It is used when the disc material is PVDF.

## Relationship between maximum allowable pressure and temperature

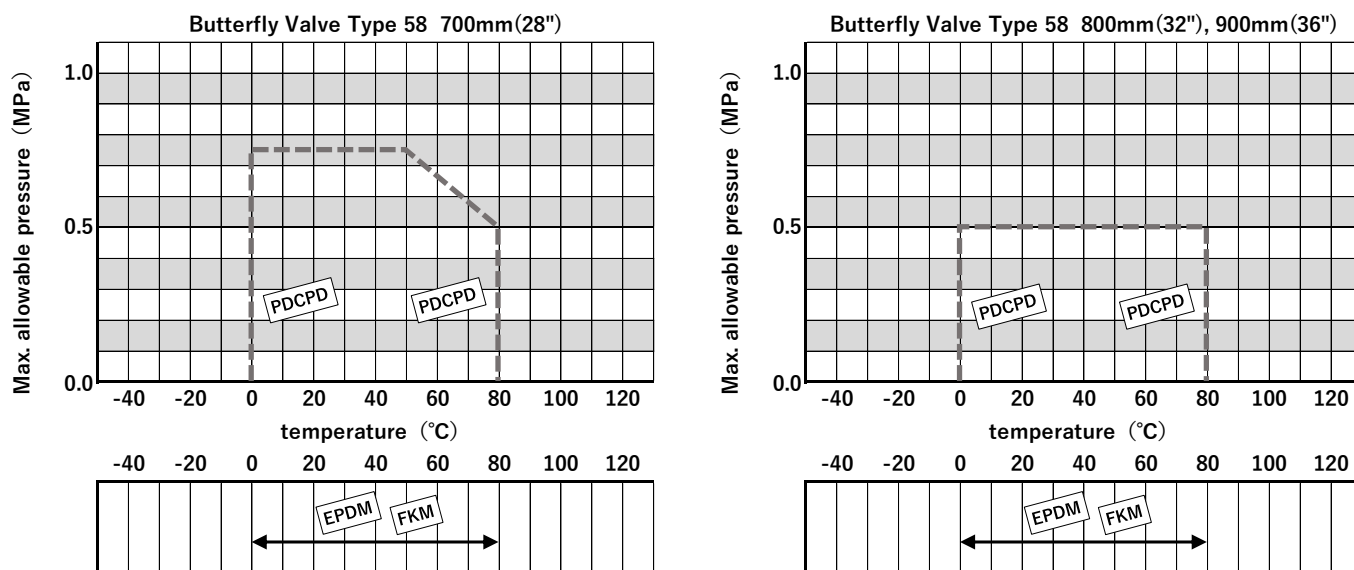

## Actuator

Operation	Applicable nominal diameter mm( inch )	Angle adjusting range	Operating Pressure Range (MPa)	Operating Temperature Range (°C)
Double action	700~900 (28"~36")	±5°	0.5~0.55	0~80

Operation	Applicable nominal diameter mm( inch )	Actuator Basic model	Air consumed (NL/ open/close) During 0.55MPa	Air supply port size
Double action	700 (28")	EPTC106-295-DA	144	NPT 3/8
	800 (32")	EPTC108-340-DA	250.1	NPT 1/2
	900 (36")			

## Standard option

Option name	Objectives and specifications	Applicable nominal diameter
Solenoid valve	<ul style="list-style-type: none"> <li>Controls opening and closing of valves</li> <li>Possible to retrofit</li> <li>Silencer with throttle valve at exhaust port provided as standard</li> </ul>	700~900mm (28"~36")
Filter-regulator	<ul style="list-style-type: none"> <li>Adjust the pressure of the operation air</li> <li>Only with solenoid valve can be retrofitted (single mounting is not possible)</li> </ul>	700~900mm (28"~36")
Speed controller	<ul style="list-style-type: none"> <li>Adjust the actuator operation time.</li> <li>Possible to retrofit</li> <li>Meter-out system</li> </ul>	700~900mm (28"~36")
Limit switch box	<ul style="list-style-type: none"> <li>Detects open/close status of valve</li> </ul>	700~900mm (28"~36")
Manual operating mechanism	<ul style="list-style-type: none"> <li>Manually operating the valve</li> </ul>	700~900mm (28"~36")

## Solenoid Valve Specification

Operation	Applicable nominal diameter mm (inch)	Model code	Air pipe bores	Power consumption
Double action	700~900 (28"~36")	VF5120-□D1-03N	NPT3/8	AC:1.55VA DC:1.5W

### VF5120-□D1-03N

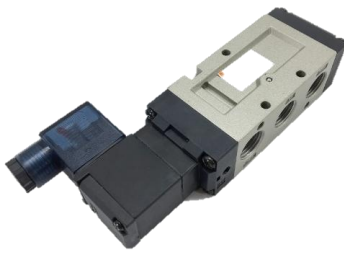

※The photo is an image

Text entry	Degree of protection
<b>1</b>	AC100V
<b>2</b>	AC200V
<b>3</b>	AC110V
<b>4</b>	AC220V
<b>5</b>	DC24V
<b>6</b>	DC12V
<b>7</b>	DC240V
<b>B</b>	AC24V

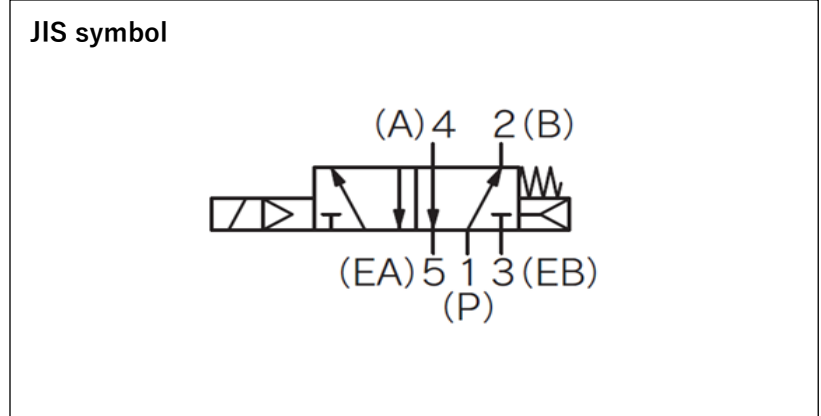
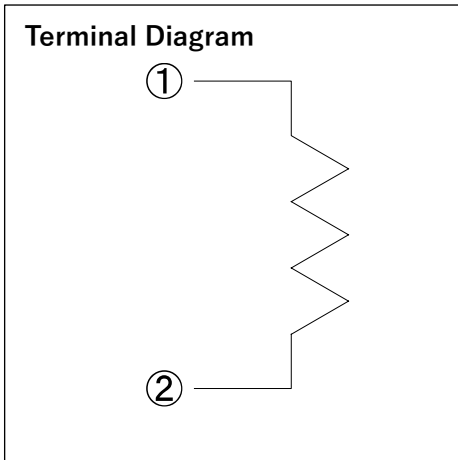

**Filter regulator specifications**

Operation	Applicable nominal diameter mm (inch)	Model code	Air pipe bores	Element filtration rate
Double action	700~900 (28"~36")	AW30-N03G-R-A	NPT3/8	5 μm

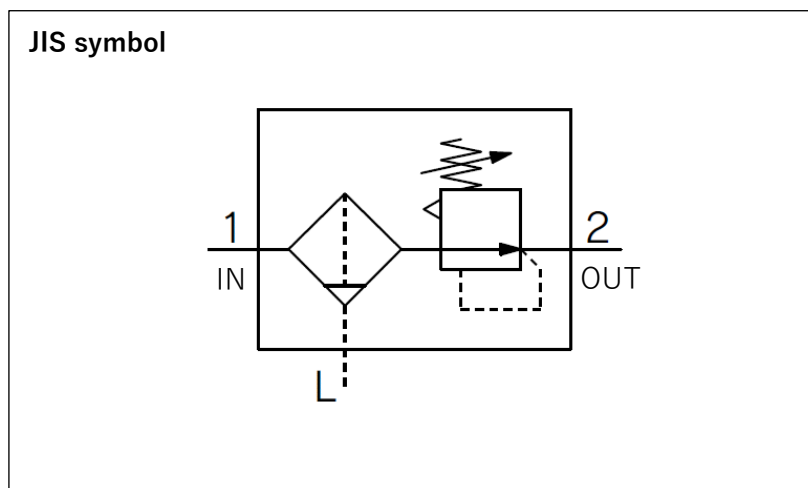

※The photo is an image

**Speed controller specifications**

Operation	Applicable nominal diameter mm (inch)	Air pipe bores	Model code
Double action	700~900 (28"~36")	NPT 3/8	AS3000-N03

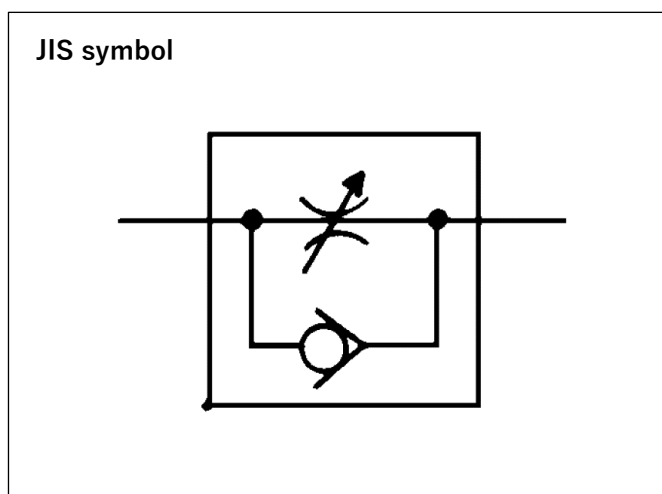

※The photo is an image

## Limit switch box specifications

Operation	Applicable nominal diameter mm(inch)	Model code	Switch contact	Protection grade	Rated voltage (V)	Resistance load (A)
Double action	700~900 (28"~36")	YT-850M3	Silver contact	IP67(IEC529)	AC250	3
					AC125	5
					DC250	0.2
					DC125	0.4
					DC30	4





※ The photo is an image

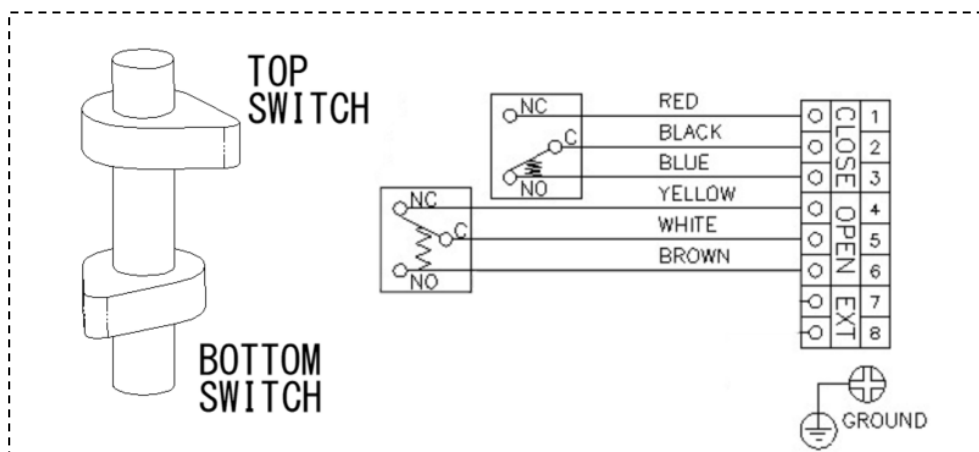

### Internal circuit

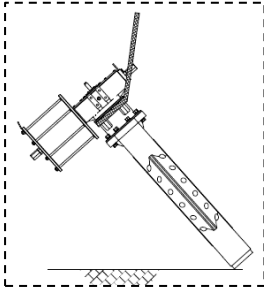

**5. Piping method**

**Wafer shape**

 <b>WARNING</b>	
 <b>Prohibition</b>	<p><b>Serious injury can result.</b></p> <ul style="list-style-type: none"> <li>▶ When hanging or slinging the valve, pay careful attention to safety and do not enter the area under the load.</li> <li>▶ Do not use the eye plate of the actuator when lifting the valve.</li> </ul>
 <b>Forcing</b>	<p><b>The valve may fall and cause injury.</b></p> <ul style="list-style-type: none"> <li>▶ When lifting the valve, hang the nylon sling on the neck at the bottom of the actuator.</li> </ul> <div style="text-align: center;">  </div>

 <b>CAUTION</b>	
 <b>Prohibition</b>	<p><b>The valve may be damaged.</b></p> <ul style="list-style-type: none"> <li>▶ Do not over-tighten when piping support is removed with a U-band, etc.</li> <li>▶ When installing piping, do not install it in the fully closed state. (The disc may get caught in the seat and the operating torque may become heavy, making it impossible to open and close it.)</li> <li>▶ Never carry or install the disc in the condition "Not feasible" in <b>Fig. 5-1</b>, as it will scratch the sealing surface of the disc.</li> <li>▶ Do not tighten the bolt nut for piping with the specified torque or more.</li> </ul>
 <b>Forcing</b>	<p><b>Risk of injury.</b></p> <ul style="list-style-type: none"> <li>▶ Be sure to perform safety inspections of the machine tool and power tool before starting operation.</li> <li>▶ Wear appropriate protective equipment for the work details when installing piping.</li> </ul> <p><b>The valve may be damaged.</b></p> <ul style="list-style-type: none"> <li>▶ Do not pull, compress, bend, or apply excessive force to the piping or valve during installation. Install the product so that no stress is applied to it.</li> <li>▶ Use a connection flange with a full-face seat. If a flange other than the full-face seat (flange adapter/backing flange, etc.) is unavoidably used, depending on the size of the valve, the corner of the flange may bite into the seat and damage the seat. Contact your nearest sales office in advance.</li> <li>▶ Check that the flange standards of each other are correct.</li> <li>▶ Before connecting the valve temporarily to the short section, attach the screw bolts (4 bolts on one side and 8 bolts on both sides) to the valve.</li> <li>▶ Fix the bolt nut for piping by tightening it from the through hole.</li> </ul>

**⚠ CAUTION**

**! Forcing**

- ▶ The product is in the "Good" state as shown in **Fig. 5-1**. Before opening or closing the valve for piping installation, be sure to return the disc to the original condition (Refer to "Good" in **Fig. 5-1**) after operation.
- ▶ If the inner diameter of the connection (flange/pipe) is small, chamfer the inside of the connection to avoid contact between the valve disc and the inner surface of the connection. (See **Fig. 5-2**.)
- ▶ The inner diameter of the connecting part should be equal to or larger than the value shown in **Table 5-1**.

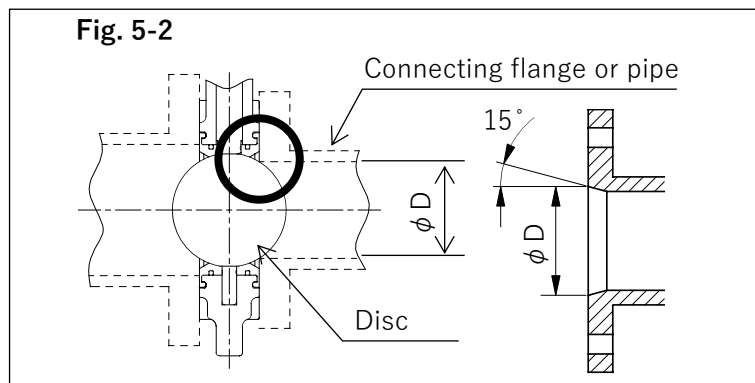
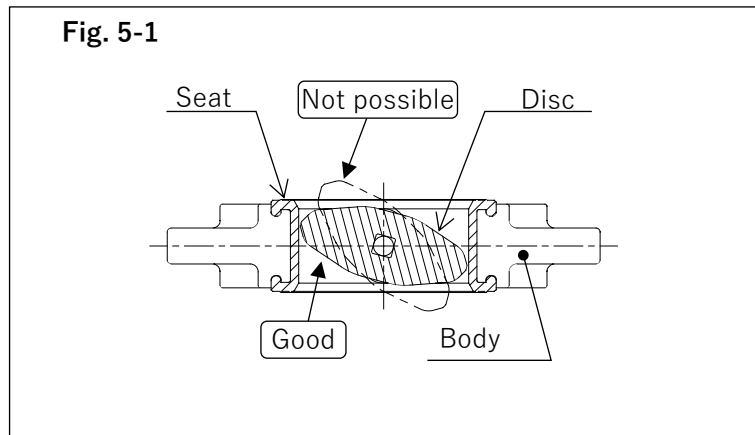

**Table 5-1** Minimum bore size

Nominal size	700 (28")	800 (32")	900 (36")
Inner diameter D	677mm (26.65")	777mm (30.59")	877mm (34.53")

Necessary items	▶ Torque wrench ▶ Spanner wrench ▶ Through-bolt ▶ Screw-in bolt ▶ Nut, Washer
	▶ Short pipe ▶ waste cloth

### Dimensions of Through Bolt and Screw-in Bolt

• The length of the bolt to be used varies depending on the connection standard and flange material. Obtain the bolt length using the following formula.

- L : Length of through bolt
- S : Thread length of through bolt
- L1: Length of screw bolt
- D : Nominal thread
- W : Between the surfaces of valves
- a : Thread depth
- b : Flange thickness
- c : Thickness of washer
- d : Thickness of nut
- e : Bolt output (Thread pitch × 3)

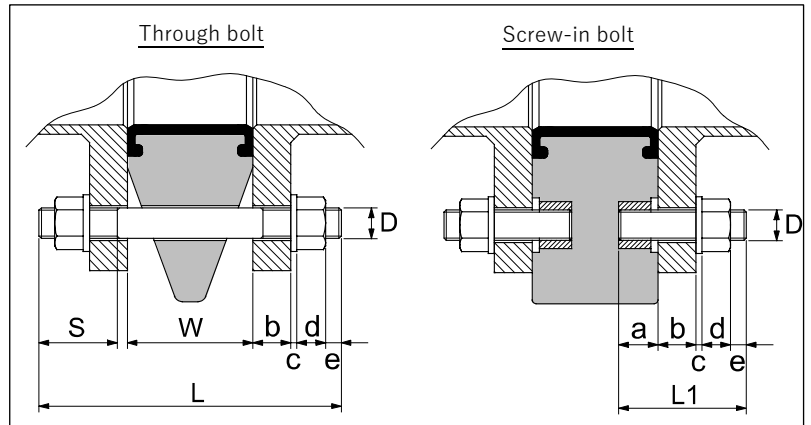

[Through bolt]	$L \geq W + (b + c + d + e) \times 2$
	$S \geq D \times 2.5$
[Screw-in bolt]	$L1 \geq a + b + c + d + e$

Nominal size			700mm (28")	800mm (32")	900mm (36")	
Common	W	Between valve faces	169mm (6.65")	198mm (7.80")	211mm (8.31")	
JIS 10K	D	Thread size	M30	M30	M30	
	a	Thread depth	28mm (1.10")	30mm (1.18")	30mm (1.18")	
	Q'ty		Through bolt (pcs.)	20	24	24
			Screw-in bolt (pcs.)	8	8	8
			Nut (pcs.)	48	56	56
	Washer (pcs.)	48	56	56		
DIN	D	Thread size	M27	M30	M30	
	a	Thread depth	28mm (1.10")	30mm (1.18")	30mm (1.18")	
	Q'ty		Through bolt (pcs.)	20	20	24
			Screw-in bolt (pcs.)	8	8	8
			Nut (pcs.)	48	48	56
	Washer (pcs.)	48	48	56		
ANSI	D	Thread size	UNC 1¼-7	UNC 1½-6	UNC 1½-6	
	a	Thread depth	28mm (1.10")	30mm (1.18")	30mm (1.18")	
	Q'ty		Through bolt (pcs.)	24	24	28
			Screw-in bolt (pcs.)	8	8	8
			Nut (pcs.)	56	56	64
	Washer (pcs.)	56	56	64		

**[Procedure]**

- 1) Set the short tube in advance. Center and short tube of the valve when the valve was raised. Place the short tube on the pedestal so that the center of the short tube is almost the same, and wipe up the flange surface of the short tube with a waste cloth.
- 2) Raise the valve. Wind the nylon sling around the neck of the valve to gradually raise the valve and wipe up the inner surface of the valve with a waste cloth.
- 3) Gradually lower the valve between the set short pipes.
- 4) Temporarily connect the short pipe and the valve. Slightly adjust the valve or short tube so that the bolt holes of the short tube generally matches the bolt hole of the valve. Move it. At this time, take the screw bolts (4 on one side and 8 on both sides) to the valve. Adjust the position of the bolt holes.
- 5) Install the through bolt and lightly tighten the nut.
- 6) After installing all the bolts lightly, gradually tighten only the through bolts to the specified torque value diagonally with a torque wrench. (See **Table 5-2** and **Figure 5-3**.)
- 7) After completing the tightening of the through bolts, gradually tighten the screw-in bolts diagonally to the specified torque value with a torque wrench. (See **Table 5-2** and **Figure 5-3**.)
- 8) Tighten all pipe bolts clockwise to the specified torque value for at least two turns. (See **Table 5-2** and **Figure 5-3**.)

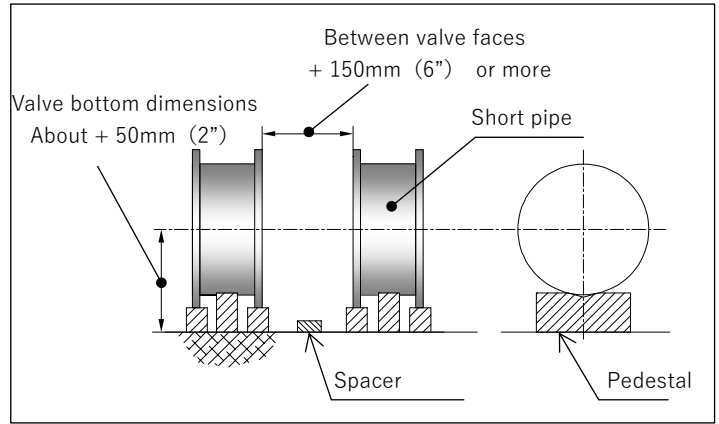

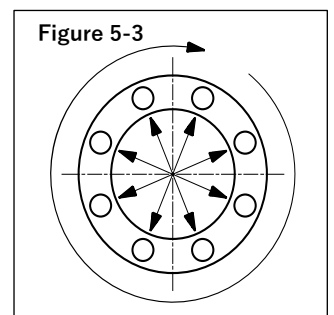
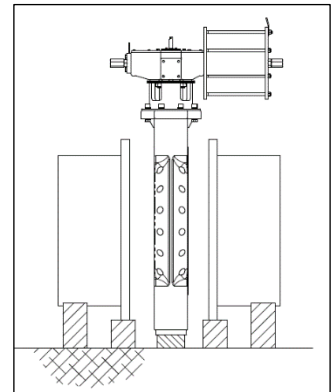

**Table 5-2 Flange tightening torque**

Nominal size	700mm (28")	800mm (32")	900mm (36")
Tightening torque N-m {kgf-cm}	130 {1,330}	130 {1,330}	170 {1,740}



## Product support

 <b>WARNING</b>	
 <b>Prohibition</b>	<p><b>The valve may be damaged or broken.</b></p> <p>▶ Do not cause large vibrations to the valve by the piping around the pump.</p>
 <b>Forcing</b>	<p><b>Damage to the valve body and piping may occur.</b></p> <p>▶ Install a valve support.</p>

Necessary items	▶ Spanner wrench ▶ U-band (with bolt) ▶ Rubber sheet
-----------------	--

### Horizontal piping [Procedure]

- 1) Place the frame under the valve.
- 2) Place a rubber sheet under the actuator, Support by the frame.
- 3) With a rubber sheet on the pipe and a U-band Fix it.

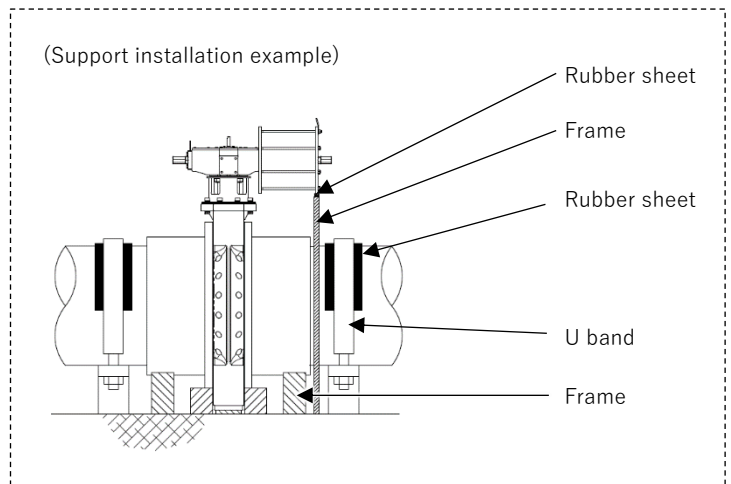

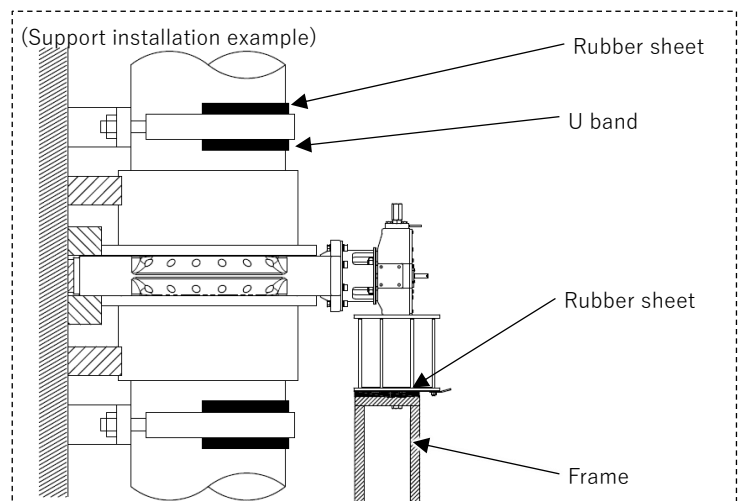

### Vertical piping [Procedure]

- 1) Place a rubber sheet under the actuator, Support by the frame.
- 2) With a rubber sheet on the pipe and a U-band Fix it.



**6. Air piping method**

 <b>WARNING</b>	
 <b>Prohibition</b>	<p><b>Otherwise, the actuator may be damaged or malfunction may result.</b></p> <ul style="list-style-type: none"> <li>▶ Do not remove the protective plug until just before connecting the air piping.</li> <li>▶ Do not overtighten the fitting for air piping.</li> </ul>
 <b>Forcing</b>	<p><b>Otherwise, the actuator may be damaged or malfunction may result.</b></p> <ul style="list-style-type: none"> <li>▶ Confirm the connection location, air piping size, and screw type from the drawing of the product before connecting the air piping.</li> <li>▶ Use clean, dehumidified and dust-free air for operation. However, when using high dry air with a dew point of -40° C or less, contact us separately.</li> <li>▶ When using the product in a place where the ambient temperature may drop below 5° C, remove moisture from the operation air to prevent freezing.</li> <li>▶ When using metal piping for air piping, use one with rust-proof treatment on the inner surface of the pipe.</li> <li>▶ Flush the inside of the air piping thoroughly before connecting the air piping.</li> <li>▶ Use sealing tape as a sealing material for air piping. If liquid sealant or liquid gasket is used, stress cracking (environmental stress cracking) may occur.</li> <li>▶ When piping air, be careful not to allow foreign matter, such as sealant, to enter the piping.</li> </ul> <p><b>This may cause galling or air leakage.</b></p> <ul style="list-style-type: none"> <li>▶ Be sure to remove any burrs on the threads of the pipe fittings.</li> </ul> <p><b>Otherwise, the actuator or optional accessories may fail.</b></p> <ul style="list-style-type: none"> <li>▶ Set the secondary side pressure of the regulator with filter to a value suitable for the equipment specifications.</li> <li>▶ Regularly drain the drain from the pressure regulator with filter.</li> </ul>

Necessary items	▶ Metal or tube for air piping ▶ Spanner wrench	▶ Fittings for metal pipes or tubes ▶ Sealing tape
-----------------	--	---



**[Procedure]**

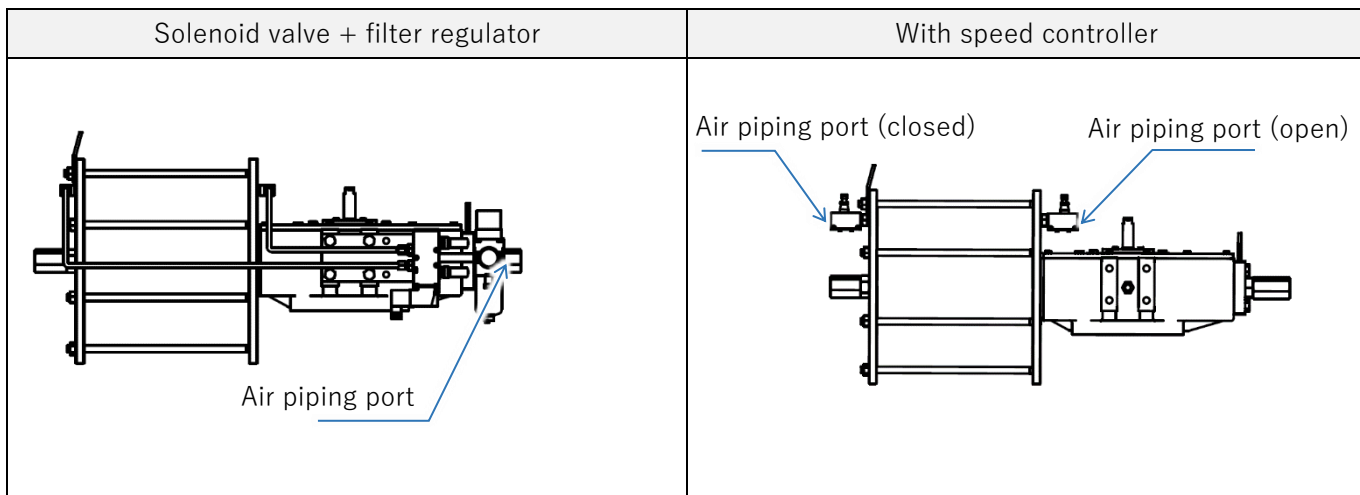
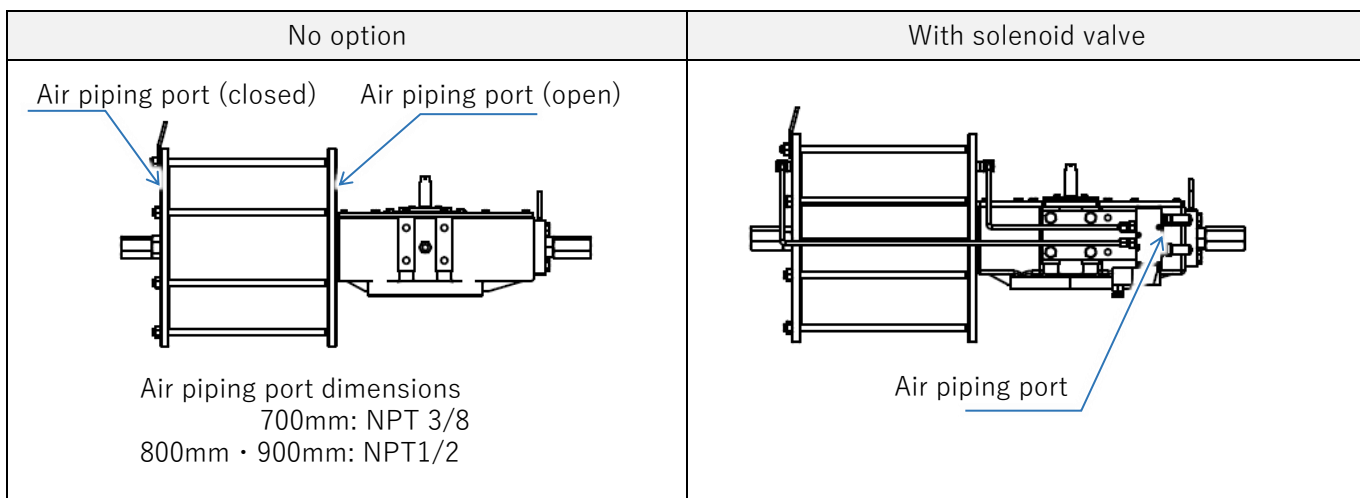

- 1) Wrap sealing tape around the male thread of the fitting, leaving approximately 3mm away from the end.
- 2) Tighten a fitting to the air piping port of the actuator or pneumatic equipment (speed controller, filter regulator, solenoid valve).
- 3) Screw the fitting with a wrench.
- 4) Install the fitting for air piping or the tube pipe.



## 7. How to Connect Options

### Limit switch

 <b>WARNING</b>	
 <b>Prohibition</b>	<p><b>Electric shock or sudden start of the machine.</b></p> <ul style="list-style-type: none"> <li>▶ Do not connect or disconnect wires to the limit switch while the power is on.</li> <li>▶ Do not connect wires in an environment where rainwater or moisture may be splashed on the wires (e.g. outdoors in rainy weather).</li> <li>▶ Do not perform wiring work with wet hands or tools.</li> </ul>
 <b>Forcing</b>	<p><b>Serious injury can result.</b></p> <ul style="list-style-type: none"> <li>▶ Be sure to perform safety inspections of the machine tool and power tool beforehand.</li> <li>▶ Wear appropriate protective equipment according to the type of work being performed.</li> </ul>

 <b>CAUTION</b>	
 <b>Prohibition</b>	<p><b>Water, dust, etc. may penetrate and cause operation failure.</b></p> <ul style="list-style-type: none"> <li>▶ Do not leave the limit switch cover open or use it.</li> </ul>
 <b>Forcing</b>	<p><b>Doing so may damage the limit switch.</b></p> <ul style="list-style-type: none"> <li>▶ Securely tighten the cover fixing screws of the limit switch.</li> <li>▶ The wire is connected using a solderless terminal with insulation covering so that it does not come into contact with the cover or housing. Please do it.</li> <li>▶ Tighten the terminal block screws securely.</li> </ul>



Preparations	<ul style="list-style-type: none"> <li style="margin-right: 10px;">▶ Phillips screwdriver</li> <li style="margin-right: 10px;">▶ Waterproof Connector (G1/2)</li> <li style="margin-right: 10px;">▶ Sealing Plug (G1/2)</li> <li style="margin-right: 10px;">▶ Flat-blade screwdriver (precision)</li> <li>▶ Wire stripper</li> </ul>
--------------	---

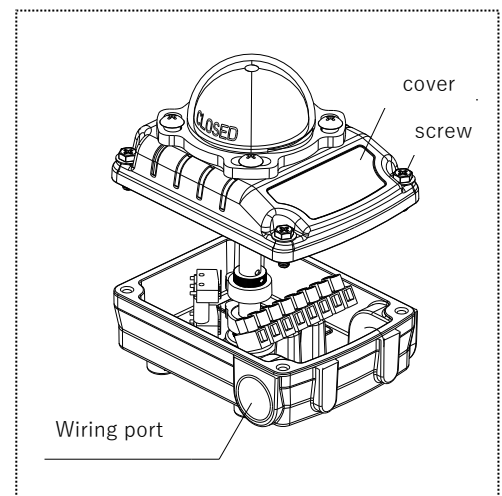

#### [Procedure]

- 1) Loosen the cover setscrew with a Phillips screwdriver and remove the cover.
- 2) With the waterproof connector (e.g. SC locking) by removing the protective cap Install.
- 3) Pass the cable through the waterproof connector and peel the outer skin of the cable with a wire stripper.
- 4) Internal circuit of "8. Limit Switch Specifications" using a flathead screwdriver for the terminal screw Connect the wires as shown in the figure.
- 5) Tighten the cover of the waterproof connector and tighten the cable.
- 6) Put the cover over, tighten the cover setscrew, and attach the cover.
  - At this time, be careful not to mistake the direction of the indicator.
  - When the red cam is hitting the switch → Make CLOSED visible.
  - When the yellow cam is hitting the switch → Make OPEN visible.
- 7) Attach the sealing plug to the unused wiring port. (There are two wiring ports.)



## Solenoid valve

 <b>WARNING</b>	
 <b>Prohibition</b>	<p><b>There is a risk of electric shock.</b></p> <ul style="list-style-type: none"> <li>▶ Do not connect wires or disconnect wires to the solenoid valve in an energized state.</li> <li>▶ Do not connect wires in an environment where rainwater or moisture may be splashed on the wires (e.g. outdoors in rainy weather).</li> <li>▶ Do not perform wiring work with wet hands or tools.</li> </ul>
 <b>Forcing</b>	<p><b>Serious injury can result.</b></p> <ul style="list-style-type: none"> <li>▶ Be sure to perform safety inspections of the machine tool and power tool beforehand.</li> <li>▶ Wear appropriate protective equipment according to the type of work being performed.</li> </ul>

 <b>CAUTION</b>	
 <b>Prohibition</b>	<p><b>Otherwise, the solenoid valve may be damaged.</b></p> <ul style="list-style-type: none"> <li>▶ Do not leave the housing and gland nut of the solenoid valve in place or use it.</li> </ul>
 <b>Forcing</b>	<p><b>Otherwise, the solenoid valve may be damaged.</b></p> <ul style="list-style-type: none"> <li>▶ Securely tighten the fixing screws of the solenoid valve.</li> <li>▶ Be careful not to lose the O-ring attached to the fixing screw.</li> <li>▶ Confirm that the power supply voltage indicated on the solenoid valve matches the voltage to be connected.</li> </ul>



Preparations	▶ Phillips screwdriver ▶ flat-blade screwdriver ▶ wire stripper
--------------	---

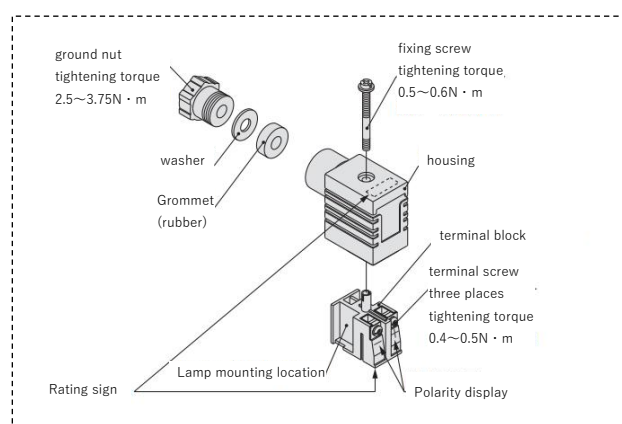

### [Procedure]

- 1) Loosen the set screw and pull the connector out of the solenoid valve terminal block.
- 2) After removing the fixing screws, insert a flat head screwdriver, etc. into the notch on the bottom of the terminal block to pry it open, and separate the terminal block from the housing.
- 3) Pass the cable in the order of gland nut and housing.
- 4) Peel off the outer skin of the cable with a wire stripper.
- 5) Loosen the terminal screw of the terminal block, insert the core of the lead wire into the terminal, and securely fix it with the terminal screw.
- 6) Secure the cord by tightening the gland nut. When connecting wires, use cable cords of the specified sizes (ø4.5 to ø7) only. These cables will not satisfy IP65 (protective construction) standards. Tighten the Ground nut and set screw within the specified range of torque.



## 8. Manual operation

 <b>WARNING</b>	
 <b>Prohibition</b>	<p><b>There is a danger of injury.</b></p> <ul style="list-style-type: none"> <li>▶ Do not supply air during manual operation.</li> </ul>
 <b>Forcing</b>	<p><b>There is a danger of injury.</b></p> <ul style="list-style-type: none"> <li>▶ Do not supply air to the actuator.</li> <li>▶ Exhaust the inside of the actuator to remove residual pressure.</li> <li>▶ Check that nothing is touching the upper output shaft.</li> </ul>

 <b>CAUTION</b>	
 <b>Prohibition</b>	<p><b>Doing so may damage the actuator.</b></p> <ul style="list-style-type: none"> <li>▶ Do not force the handle to rotate further from the fully opened or closed position.</li> </ul>
 <b>Forcing</b>	<p><b>Doing so may cause the actuator to malfunction.</b></p> <ul style="list-style-type: none"> <li>▶ Always use the product within the range of the indicated product specifications.</li> <li>▶ When operating the product with a solenoid valve manually, remove the solenoid valve from the actuator.</li> </ul>

### Manual operation

- 1) Check if the special oil cap with air hole (No. 10) is set.
- 2) Close the bypass valve (No. 7).
- 3) Select the position (open/close) with the directional control valve (No. 3).
- 4) Connect the pipe for manual operation to the hand pump (No. 6).
- 5) Operate the valve by moving the pipe up and down.

### Switch to automatic operation

#### [Procedure]

- 1) Move the directional control valve to the middle position.
- 2) Open the hydraulic bypass valve.

#### [How to check the hydraulic oil quantity]

- 1) Remove the oil plug, insert a pipe, etc., and check the oil level.
- 2) Supply oil if the height of the oil level from the bottom of the tank is less than 70mm.

#### Hydraulic oil specification

- Manufacturer: SK Corporation
- Model: ZIC
- Viscosity (40i): 46 cSt
- Viscosity (100i): 8.7 cSt
- ISO : ISO VG 46

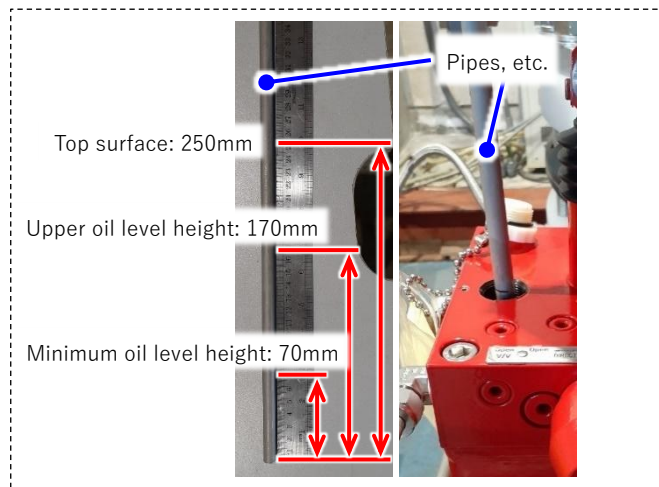
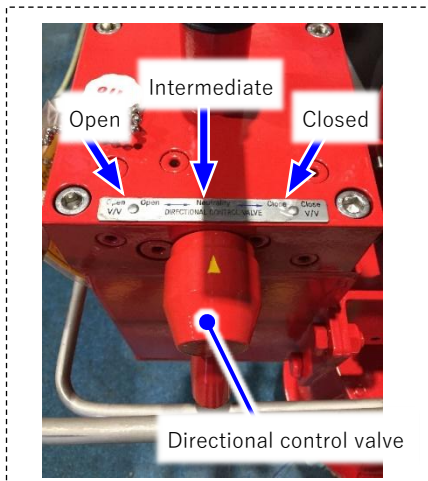
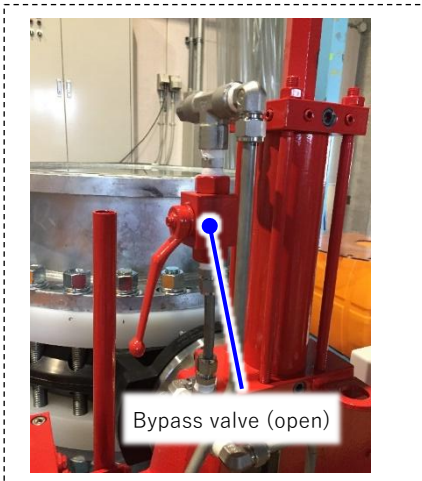
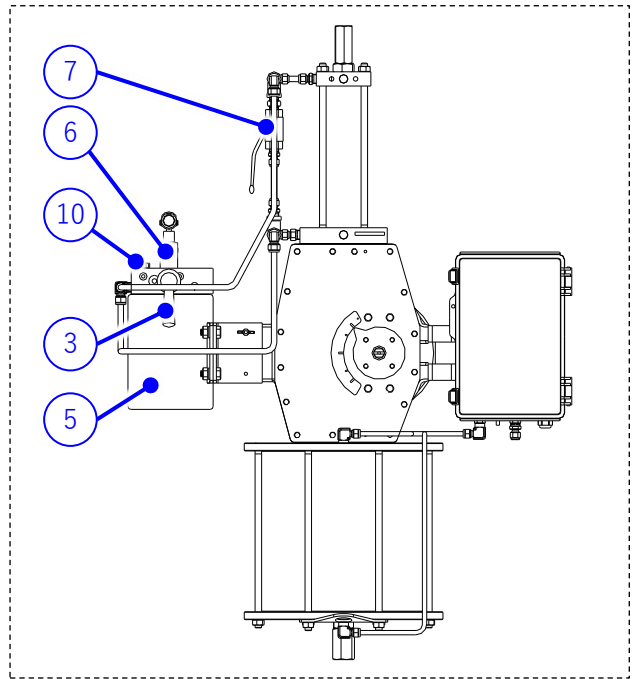
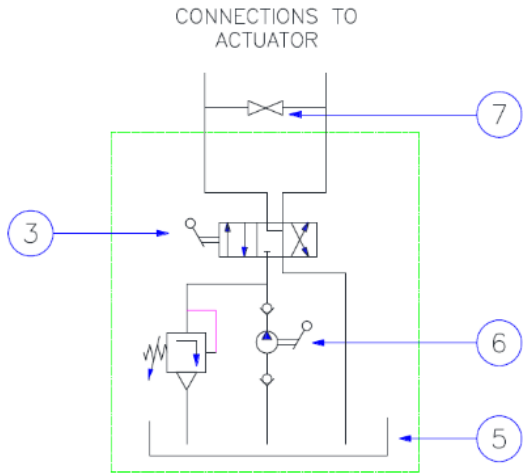

**9. Air Operation**

**CAUTION**



**Forcing**

**Doing so may damage the actuator.**

▶ Always use the product within the range of the indicated product specifications.

**[Procedure]**

- 1) Supplies air to the air piping port.
- 2) Check that the air supply side and the display position match.
  - ※The position of the pointer when fully closed may not reach the position shown in the figure slightly due to the tightening allowance of the disc.
- 3) Stop the air supply.

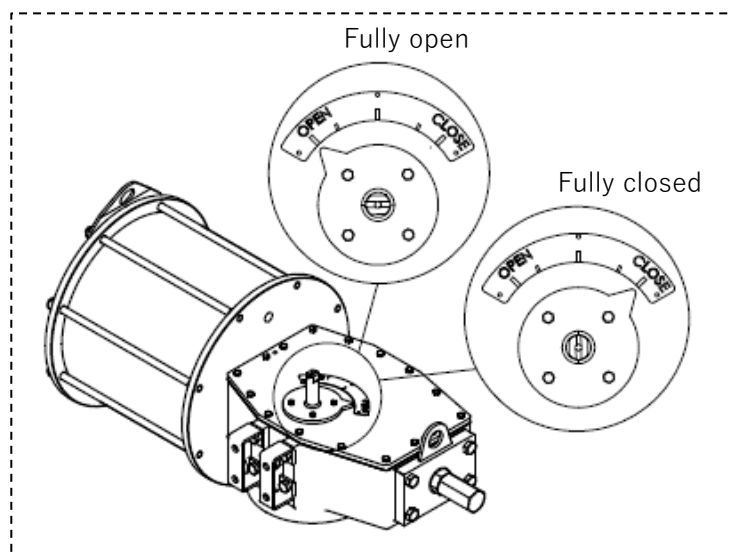

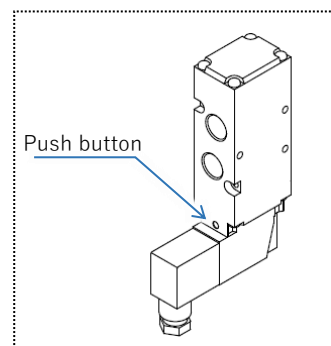

**[With solenoid valve]**

- 1) Check that the specified air is supplied.
  - Check that the operation is as shown in the table below by pressing the push button below the solenoid valve terminal cover.
- 2) Confirm that the solenoid valve operates as shown in the table below by energizing or de-energizing.
- 3) Turn off the power to the solenoid valve.



Push button	Power supply	Double action
Press	Energizing	Valve fully open
Do not press	De-energizing	Valve fully closed

## 10. How to adjust the stopper

 <b>WARNING</b>	
 <b>Prohibition</b>	<p><b>There is a danger of injury.</b></p> <p>▶ Do not supply air during adjustment.</p>
 <b>Forcing</b>	<p><b>Doing so may cause the actuator to malfunction.</b></p> <p>▶ Be sure to fix the stopper with the lock nut after adjustment. (Do not use excessive force to tighten.)</p>

Necessary items	▶ Spanner wrench
-----------------	------------------

### [Procedure]

- 1) Fix the lock nut on the side to be adjusted (fully open or fully closed) with a spanner wrench, and remove the feedback nut.
  - \* Do not damage the O-ring.
- 2) Rotate the stopper with a spanner in the direction you want to adjust.

Direction to adjust	Rotate clockwise (clockwise)	Rotate Left (counterclockwise)
Open side	Decrease the opening	Increase the opening
Closed side	Increase the opening	Decrease the opening

- 3) Rotate the stopper with a spanner in the direction you want to adjust.
  - \* Do not over tighten. (The O-ring may be damaged and air leakage may occur.)
- 4) Open the main valve of the air and check if the opening is the one that you want to adjust by the operation with the air. To adjust again, repeat **1) 2) 3)**.

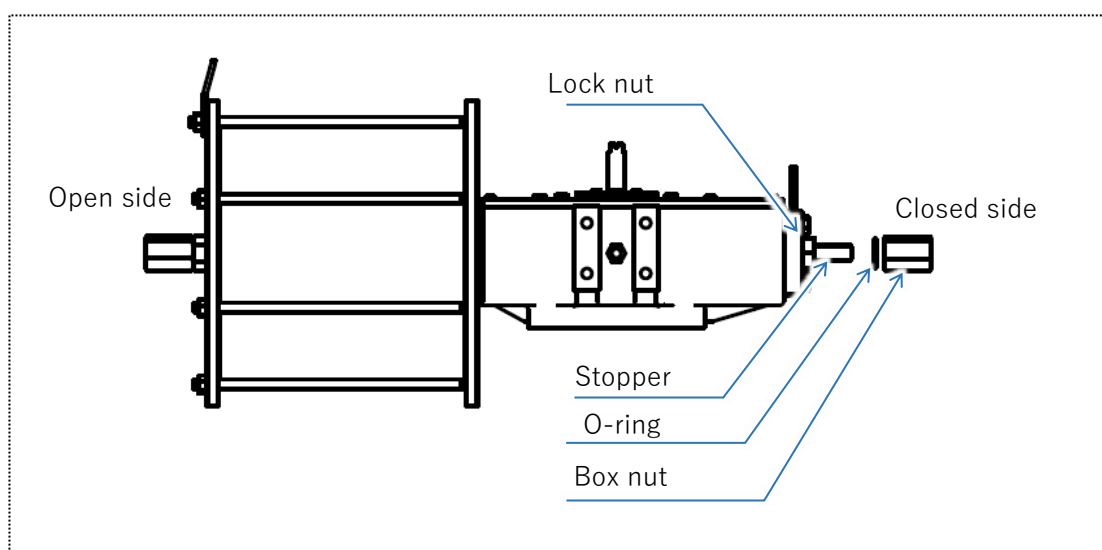

## 11. How to adjust open/close speed

Necessary items	▶ Spanner wrench
-----------------	------------------

### [Procedure]

- 1) While holding the speed controller adjustment knob with your finger, rotate the lock nut counterclockwise to release the adjustment knob.
- 2) Turn the adjustment knob clockwise until it does not turn.  
\* Do not turn it too hard. (Damage may occur.)
- 3) Supplies air to the speed controller.
- 4) Turn the adjusting knob of the open-side speed controller little by little to adjust the opening/closing speed.
- 5) When the desired speed is achieved, hold the adjustment knob with your finger and rotate the lock nut clockwise to secure the adjustment knob.  
\* Do not tighten the lock nut with excessive force. (Damage may occur.)

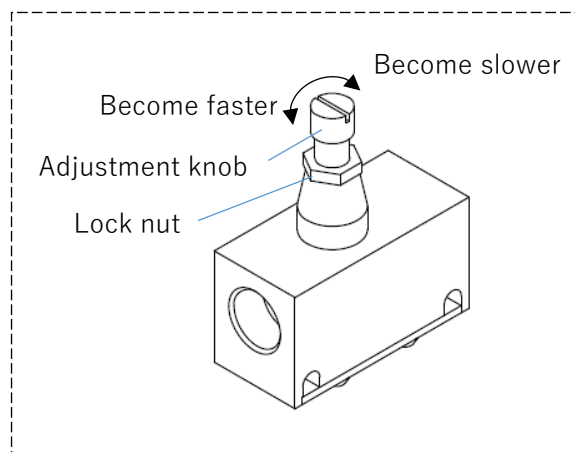

## 12. Inspection item

<b>CAUTION</b>	
<b>Forcing</b>	<p><b>Leakage may occur due to changes in temperature or aging during long-term storage, resting, or use.</b></p> <p>▶ Please enforce daily inspection and periodic inspection.</p>

### Daily inspection

Inspection items and method	Guideline of judgment	Check point	Treatment method
External leakage (visual inspection)	For leakage No	Pipe flange connection	<ol style="list-style-type: none"> <li>1) Retighten the pipe bolts to the specified torque</li> <li>2) Remove the valve from the pipe and re-tighten the pipe bolts</li> </ol>
		Top flange and bottom flange of the valve	Remove the valve from the pipe and replace the valve
		Surface of the entire valve	Remove the valve from the pipe and replace the valve
Internal leakage (visual and measurement)	For leakage No	Leakage to secondary side when valve is fully closed	<ol style="list-style-type: none"> <li>1) Adjusting the stopper position of the actuator</li> <li>2) Inspection and cleaning of sealing surfaces</li> <li>3) Remove the valve from the pipe and replace the valve</li> </ol>
		Measured values of flowmeters, pressure gauges, etc.	<ol style="list-style-type: none"> <li>1) Adjusting the stopper position of the actuator</li> <li>2) Inspection and cleaning of sealing surfaces</li> <li>3) Remove the valve from the pipe and replace the valve</li> </ol>
Operating position Displacement (visual inspection)	In a shift No	Actuator opening display	<ol style="list-style-type: none"> <li>1) Adjusting the stopper position of the actuator</li> <li>2) Replace actuator or valve</li> </ol>
Abnormal noise (hearing)	Abnormal noise No	Valves and actuators	Remove the valve from the pipe and replace the valve or actuator
		Piping around the valve	Reconfirm the conditions of use
Valve damage	No cracks	Surface of the entire valve	Remove the valve from the pipe and replace the valve

**Periodic inspection**
**\* Guideline for the inspection cycle: 3 months**

Inspection items and method	Guideline of judgment	Check point	Remedy for malfunctions
Vibration (palpation)	To differences from other parts No	Valves and actuators	Recheck the operating conditions and remove the source of vibration
			Remove the valve from the pipe and replace the valve or actuator
		Piping around the valve	Recheck the operating conditions and remove the source of vibration

**Periodic inspection**
**\* Guideline of the inspection cycle: 6 months**

Inspection items and method	Guideline of judgment	Check point	Remedy for malfunctions
On the manual handle Operability (touch)	Smoothly Turning	Manual operation unit	Remove the valve from the pipe and replace the valve or actuator
Of bolts Looseness (visual and palpation)	Loose No	between actuator and valve	Retighten the mounting screws with a 100 N-m.
		For flange piping	Retighten the pipe bolts to the specified torque
Water intrusion (visual inspection)	Of the intrusion No	Inside the actuator	Replace the actuator
Entry of foreign matter (visual inspection)	Of the intrusion No	Inside the actuator	Replace the actuator
Corrosion Or rust (visual inspection)	Corrosion or Of rust No	Appearance of the product and in the actuator	Remove the valve from the pipe and replace the valve or actuator
Product damage	No scratches, cracks, or deformation	Appearance of the product	Remove the valve from the pipe and replace the valve or actuator

### 13. Troubleshooting

Problem	Cause	Treatment
The hand pump does not move during manual operation.	The valve is already fully open (or fully closed)	Rotate the handle in the opposite direction
	Air is supplied to the actuator. Or residual pressure remains	Stop air supply and release internal pressure
	Foreign matter caught in valve	Remove the valve from the piping, disassemble it, and remove foreign matter
	Piping stress is applied to the valve	Remove the piping stress
	The torque of the valve has increased due to the effects of the fluid (temperature, components, pressure, etc.)	Reconfirm the conditions of use
Do not open or close by air operation.	The solenoid valve is turned off	Turn on the power
	Connection to the solenoid valve is disconnected	Check the connection condition again
	Air is not supplied	Supply air
	The power voltage of the solenoid valve is different	Check the voltage with a tester and set the correct voltage
	Solenoid valve voltage is low	Check the voltage with a tester and set the correct voltage
	The speed controller adjustment knob is turned all the way to the right	Turn the speed controller knob to the left
	Foreign matter caught in valve	Remove the valve from the piping, disassemble it, and remove foreign matter

**Troubleshooting (continued)**

Problem	Cause	Treatment
Do not open or close by air operation.	Piping stress is applied to the valve	Remove the piping stress
	The torque of the valve has increased due to the effects of the fluid (temperature, components, pressure, etc.)	Reconfirm the conditions of use
	Interference between the disc and pipe	Loosen the pipe bolt, align the shaft core, and reinstall
	Excessive tightening of pipe bolts	Loosen the pipe bolts and re-tighten them with an appropriate torque
	Disc interference due to sheet peeling	Loosen the pipe bolt, adjust the position of the seat, and reinstall the seat
	The actuator does not move due to external corrosion of the actuator	Stop using the product immediately and replace the actuator
Fluid leaks even when fully closed (internal leak)	High fluid pressure	Use below the maximum allowable pressure
	Seat or disc is worn or scratched	Remove the valve from the pipe and replace the valve
	Missing parts	Remove the valve from the pipe and replace the valve
	Foreign matter caught in valve	Remove the valve from the piping, disassemble it, and remove foreign matter
	Piping stress is applied to the valve.	Remove the piping stress

**Troubleshooting (continued)**

Problem	Cause	Treatment
Fluid leaks from valve (external leak)	O-ring is scratched, worn, melted, or altered	Stop using the product immediately, remove the valve from the piping, and replace the valve
	Scratches or wear are found on the sliding or fixing surfaces of the O-ring	Stop using the product immediately, remove the valve from the piping, and replace the valve
	Valve is cracked or broken	Stop using the product immediately, remove the valve from the piping, and replace the valve
Actuator is operating but valve is not open or closed	Damaged stem or fitting	Stop using the product immediately, remove the valve from the piping, replace the relevant part, or replace the valve
Actuator is corroded	The watch is exposed to water, chemical liquids, or other liquids	Stop using the product immediately, remove the valve from the piping, and replace the actuator
Valve is corroded or deformed	The watch is exposed to water, chemical liquids, or other liquids	Stop using the product immediately, remove the valve from the piping, and replace the valve

## 14. How to inquire about defects or replacement

 <b>WARNING</b>	
 <b>Forcing</b>	<p><b>When burnt, toxic gas is generated.</b></p> <ul style="list-style-type: none"> <li>▶ When disposing of the product or parts, please dispose of them according to the guidelines of each local authority by a professional disposal company.</li> </ul>

**Contact**

Contact the nearest distributor, our sales office, or our web website for inquiries about this product.

**[User's Manual]**

Butterfly Valve 58 Pneumatic Actuated

Type FL

700mm (28")~900mm (36")



The product names, logos, and other trademarks mentioned in this instruction manual are all registered trademarks of ASAHI YUKIZAI CORPORATION.

These trademarks are the intellectual property of ASAHI YUKIZAI CORPORATION and may not be used without permission.

Nothing in this manual grants a license to use the trademarks, either expressly or implicitly.

For further details regarding registered trademarks, please contact ASAHI YUKIZAI CORPORATION.

<https://www.asahi-yukizai.co.jp/en>

Information in this manual is subject to change without notice.

**May 2026**

**[User's Manual]** Butterfly valve Type 58 Pneumatic Actuated Type FL 700mm (28") ~900mm (36")