

Butterfly valve type 58
Electric Actuated
Type A
700mm (28") ~ 900mm (36")

User's Manual



Thank you very much for choosing our product.

This instruction manual is for your safety to use our product.

This manual contains important information. Be sure to read this manual before handling the product.

After reading this manual, the user can refer to it at any time.

Please be sure to keep it.

ASAHI YUKIZAI CORPORATION

-SAFETY PRECAUTIONS-



This instruction manual is written on the assumption that the person who handles our products has a basic knowledge of our products, electrical equipment, machinery, control, etc., and it contains technical terms depending on the handling contents.

Please read this manual carefully and fully understand the contents and observe the safety precautions for proper use.

In this manual, the warning, caution, prohibition, and enforcement are categorized together with the symbol to inform the situation and scale of human injury or property damage.

Failure to observe this precaution may result in unexpected failure or damage. Be sure to observe this precaution.

<WARNING/CAUTION displays>

 WARNING	Indicates a potentially hazardous situation which, if not avoided, could result in death or serious injury.
 CAUTION	Indicates a potentially hazardous situation which, if not avoided, may result in minor or moderate injury or property damage.

<Prohibited/Forced display>



 Prohibition	In the handling of the product, it is prohibited to do it in "Do not do it".
 Forcing	In the handling of the product, it is forced by "contents to be carried out without fail".

Table of contents

1. Our product warranty coverage	4
Applicable to	4
Warranty Period.....	4
Guaranteed range.....	4
Disclaimer.....	4
2. Safety Instructions	5
Unpacking, Transportation and Storage.....	5
Product Handling.....	6
3. Name of each part	8
4. Product Specifications	9
Product model code list.....	9
Relationship between maximum allowable pressure and temperature	9
Actuator.....	10
Wiring Diagram	11
Standard option	12
5. Piping method	13
Wafer shape	13
Product support.....	18
6. Electrical Wiring	19
7. Commissioning method	20
Manual operation	20
Automatic operation	21
8. How to adjust the limit switch	22
9. Inspection item	23
Daily inspection	23
Periodic inspection.....	25
10. Troubleshooting	26
11. How to inquire about defects or replacement	29
Contact	30

1. Our product warranty coverage

Unless otherwise stated in the Contract or Specifications, etc., the warranty for the piping material products (hereinafter referred to as "applicable products") such as valves manufactured or sold by us is as follows.

Applicable to

This warranty applies only when the product is used in Japan. If you intend to use the product overseas, please contact us.

Warranty Period

The warranty period is one year after delivery.

Guaranteed range

In the event of failure or malfunction due to our responsibility during the above warranty period, we will replace or repair the product with a substitute free of charge.

Provided, however, that even within the warranty period, the warranty shall not apply to any of the following cases (charged service).

- ▶ When the storage, operating conditions, precautions, etc. described in the specifications, instruction manual, etc. are not adhered to in the construction, installation, handling, maintenance, etc.
- ▶ Defects, such as the design of the customer's equipment or software, caused by other than the target product.
- ▶ The fault is due to modification or secondary processing of the product by something other than us.
- ▶ In the case of a failure which can be deemed to have been avoided if the periodic inspection described in the instruction manual, etc. or the maintenance or replacement of consumable parts has been performed normally.
- ▶ The component is used for purposes other than the product's intended use.
- ▶ Failure or malfunction due to causes that could not be foreseen by our level of science and technology at the time of shipment.
- ▶ The fault is due to an external factor that is not our responsibility, such as natural disaster or disaster.



Disclaimer

- ▶ The warranty will not cover secondary damage (damage to equipment, loss of opportunity, loss of profit, etc.) or any other damage caused by the failure of our product.
- ▶ Although we strive to improve the quality and reliability of our products, we do not guarantee their integrity. Especially when using this product for equipment that may infringe human life, body or property, take appropriate safety design measures, etc., with full consideration of problems that may normally occur. We assume no responsibility for such use if we have not obtained our consent in advance in writing of specifications, etc.
- ▶ Please observe the product specifications and precautions when using our products. We shall not assume any responsibility for any damage to the customer caused by the customer's negligence. However, this does not apply to damage caused by a defect in our product.



2. Safety Instructions



Unpacking, Transportation and Storage

 WARNING	
 Prohibition	<p>Serious injury can result.</p> <ul style="list-style-type: none"> ▶ Do not stand the lifting or slinging of the valve under a suspended load for safety.

 CAUTION	
 Prohibition	<p>The valve can be damaged, damaged, or leak.</p> <ul style="list-style-type: none"> ▶ Do not subject the product to impact by throwing, dropping or hitting. (risk of damage or breakage) ▶ Do not scratch or pierce the product with sharp objects (such as a knife or hand hook). ▶ Do not pile up cardboard boxes forcefully to prevent the load from collapsing. ▶ Avoid contact with coal tar, creosote (a wood preservative), white pesticides, insecticides, paints, etc. (Damage may occur due to swelling.) ▶ Do not hang the handle when transporting the valve.
 Forcing	<p>The valve can be damaged, damaged, or leak.</p> <ul style="list-style-type: none"> ▶ Keep in cardboard until just before piping, and store indoors (at room temperature) away from direct sunlight. Also, avoid storing the product in places of high temperature. (The strength of cardboard packaging decreases when it gets wet. Be very careful when storing and handling it.) ▶ After unpacking, make sure that the product is correct and that it meets the specifications. ▶ Clean the inner surface of the valve with a clean cloth after removing the product from the packing material.

Product Handling

 WARNING	
 Prohibition	<p>Serious injury can result.</p> <ul style="list-style-type: none"> ▶ Do not disassemble the actuator. ▶ Never touch the moving parts during operation. (Hand or arm may be caught.) ▶ If positive pressure gas is used for our resin piping material, a dangerous condition may occur due to the repulsive force peculiar to compressible fluids even if the pressure is the same as the water pressure. Therefore, be sure to take safety measures for the surrounding area, such as covering the piping with protective materials. If you have any questions, contact your nearest dealer. ▶ When conducting a leak test of a pipe line after completion of piping construction, check with water pressure. If gas tests are unavoidable, consult your nearest sales office in advance.
 Forcing	<p>There is a danger of injury.</p> <ul style="list-style-type: none"> ▶ Check the voltage on the power supply and nameplate before use. If a different voltage is used, it may cause damage or malfunction of the instrument. ▶ Perform manual operation after confirming that the actuator is not operated by the motor.

 CAUTION	
 Prohibition	<p>The valve can be damaged, damaged, or leak.</p> <ul style="list-style-type: none"> ▶ Do not step on the valve or place heavy objects on it. (Damage may occur.) ▶ Keep away from fire and hot objects. (There is a risk of deformation, damage or fire.) ▶ Do not use the product in places where it may be submerged. ▶ Keep the temperature and pressure of the fluid within the allowable range. (The maximum allowable pressure includes water hammer pressure. The valve may be damaged if it is used outside the allowable range.)

 **CAUTION**

 **Forcing**

There is a danger of injury.

- ▶ Pay attention to the atmosphere where the valve is installed. Especially, avoid installing the product where it is exposed to sea breezes, corrosive gas, chemical liquids, sea water, steam, etc.
- ▶ Ensure sufficient space for maintenance and inspection.

Doing so may cause the actuator to stop moving.

- ▶ Select and use an appropriate material. (Depending on the type of chemical liquid, the parts may be damaged. Contact your nearest sales office in advance for details.)
- ▶ Use fluids containing crystalline material under conditions that do not recrystallize. (The valve will not operate normally.)
- ▶ Avoid installing the product in a place where water or dust is constantly splashed, in a place exposed to direct sunlight, or in a place with corrosive gas or bad atmosphere, or provide a cover to cover the entire product. (The valve will not operate normally.)

The valve can be damaged, damaged, or leak.

- ▶ Perform periodic maintenance. (Leakage may occur due to changes in temperature or aging during long-term storage or shutdown, or during use.)
- ▶ Provide adequate support when installing the valve. (Excessive force is applied to the valve or piping, which may cause damage.)
- ▶ Always use the product within the range of the indicated product specifications.
- ▶ Avoid places with corrosive gases or poor atmospheres, and provide a cover or the like to cover the entire area.
- ▶ If you notice an unusual odor, heat, or smoke, immediately turn off the power supply. (There is a possibility that a fire may occur if you use the watch without feeling any abnormality. If any abnormality is found, contact the dealer from which you purchased the watch or your nearest sales office for inspection.)
- ▶ Use the supplied handle for manual operation.
- ▶ When using in an explosive atmosphere, make sure that the actuator conforms to the explosion-proof specifications.
- ▶ Keep the ambient temperature of the installation site between -30° C and 70° C.
- ▶ Do not leave the actuator in a soil or a water reservoir other than the water resistant type.
- ▶ When used with a high temperature fluid, the misalignment of the valve and flange shaft may cause sheet damage. Exercise due caution when installing the valve.
- ▶ Use a connection flange with a full-face seat. If a flange other than the full-face seat (flange adapter/backing flange, etc.) is unavoidably used, depending on the size of the valve, the corner of the flange may bite into the seat and damage the seat. Contact your nearest sales office in advance.
- ▶ Read the instruction manual carefully and fully understand the installation, operation, adjustment, and inspection of the product before starting installation.

3. Name of each part

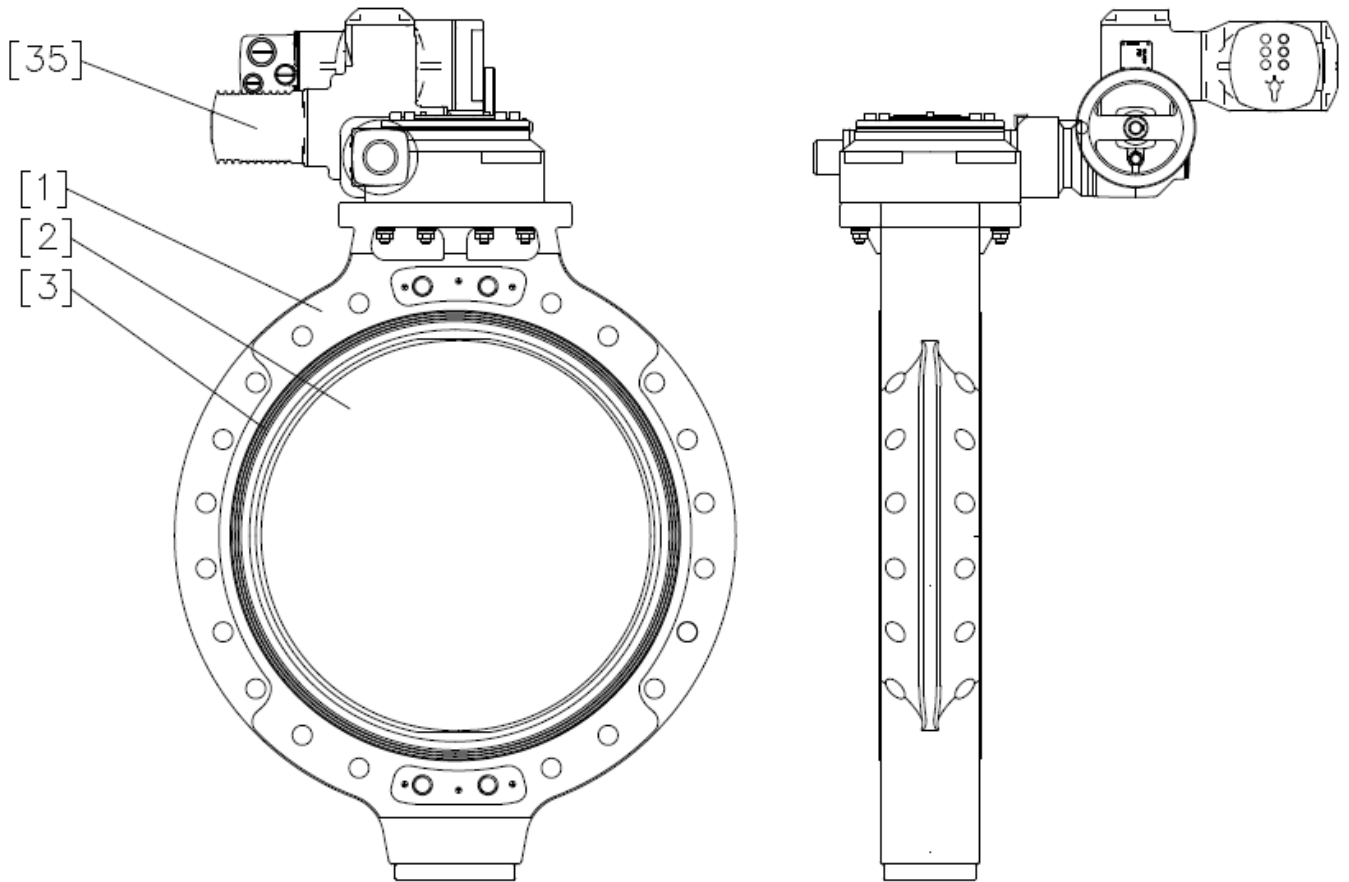

[1]	Body	[35]	Actuator
[2]	Disc		
[3]	Seat		

4. Product Specifications

Product model code list

Actuation	Type	Operating system	Body material	Seal material	Connection	Standard	Size	High purity series	Disc PVDF
A	58	**	D	*	W	*	***	0	0Q
A Automatic	58 Type 58	A4 Electric Type A 400VAC 3 φ A5 Electric Type A 220VAC 3 φ A6 Electric Type A 230VAC 3 φ A7 Electric Type A 380VAC 3 φ	D PDCPD	E EPDM V FKM	W Wafer	1 JIS 10K D DIN A ANSI	700 700mm (28") 800 800mm (32") 900 900mm (36")	0 Non	It is used when the disc material is PVDF.

Relationship between maximum allowable pressure and temperature

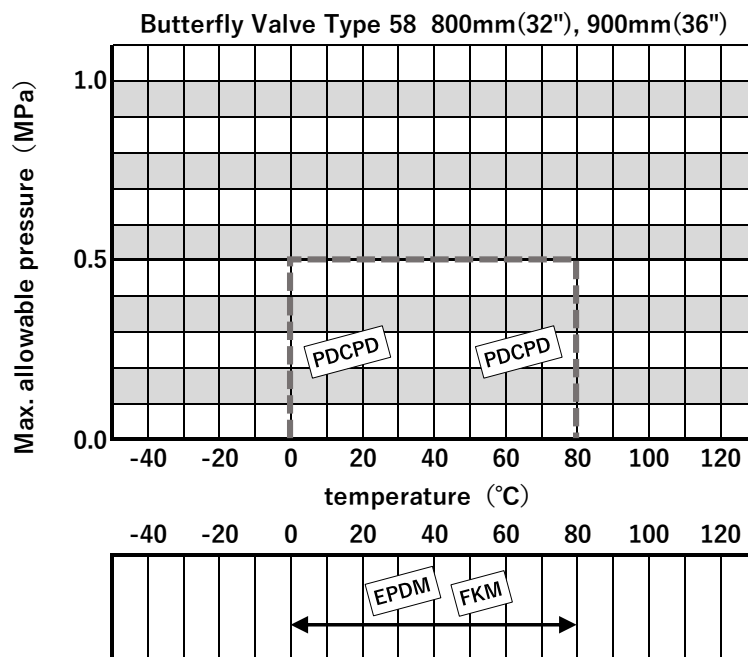
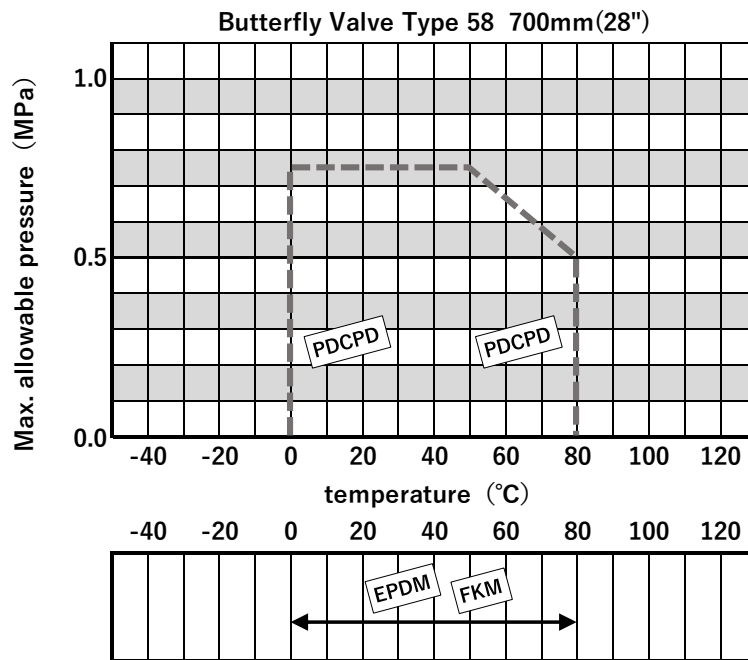

Actuator

■ Basic specifications

Nominal size		700mm (28")	800mm (32")	900mm (36")
Actuator model		SA10.2_AM01.1_GS125.3	SA10.2_AM01.1_GS160.3	
Cycle time (sec) 50Hz / 60Hz		75 / 64	74 / 62	
Protective structure		IP68	IP68	
Circuit operation		24VDC	24VDC	
Motor start current (A) 50Hz / 60Hz	220VAC	19 (60Hz only)	35 (60Hz only)	
	230VAC	15 (50Hz only)	28 (50Hz only)	
	380VAC	8.9 / 11	17 / 20	
	400VAC	8.5 / 10	16 / 19	
Motor rated current (A) 50Hz / 60Hz	220VAC	5.7 (60Hz only)	9.8 (60Hz only)	
	230VAC	4.5 (50Hz only)	7.8 (50Hz only)	
	380VAC	2.7 / 3.3	4.7 / 5.7	
	400VAC	2.6 / 3.1	4.5 / 5.4	
Manual operation handle revolution		About 440	About 884	
Cable connector size		G3/4 × 2, G1-1/4 × 1	G3/4 × 2, G1-1/4 × 1	
Motor rated output (W)	220VAC	0.4 (60Hz only)	0.7 (60Hz only)	
	230VAC	0.4 (50Hz only)	0.7 (50Hz only)	
	380VAC	0.4 / 0.4	0.7 / 0.7	
	400VAC	0.4 / 0.4	0.7 / 0.7	
Motor insulation type		F	F	
Motor rated time		S2-15Min.	S2-15Min.	
Limit switch capacity		Max. 250VAC 0.5A	Max. 250VAC 0.5A	
Space heater rated output (W)		5-20	5-20	
Ambient temperature (°C)		-30 ~ +70	-30 ~ +70	

Wiring Diagram

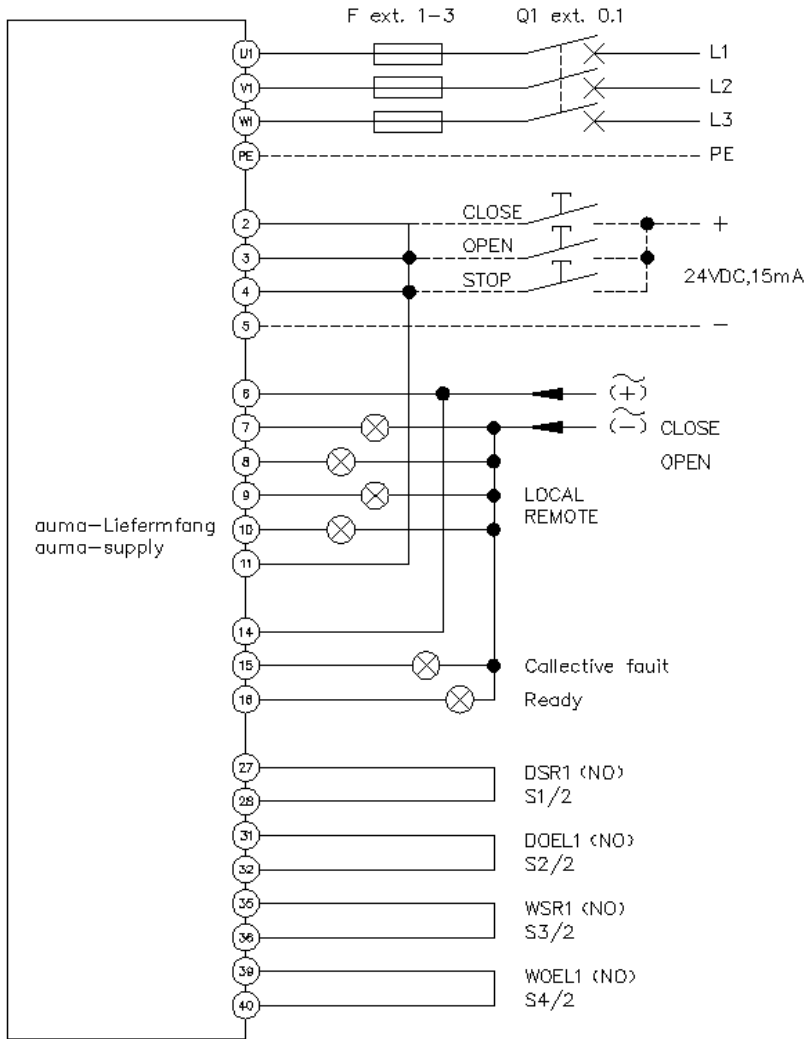

Standard option
■ OPTION COMBINATION

COMBINATION NO.	1	2
SPACE HEATER	●	●
OUTPUT CONTACT LIMIT SWITCH	●	●
POTENTIOMETER		●
OPENING TRANSMITTER	●	●



NOTE : ● Indicates that the feature is provided as standard.

■ OPTION LIST

OPTION TYPE	MANUFACTURER	BASIC SPECIFICATIONS
SPACE HEATER	auma	INCLUDED AS STANDARD.
OUTPUT CONTACT LIMIT SWITCH	auma	INCLUDED AS STANDARD.
POTENTIOMETER	auma	RESISTANCE: 0.2kΩ
OPENING TRANSMITTER	auma	signal output : 4-20mA

5. Piping method

Wafer shape

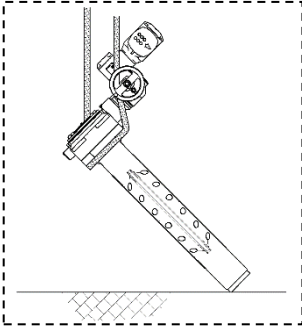
 WARNING	
 Prohibition	<p>Serious injury can result.</p> <ul style="list-style-type: none"> ▶ When hanging or slinging the valve, pay careful attention to safety and do not enter the area under the load.
 Forcing	<p>The valve may fall and cause injury.</p> <ul style="list-style-type: none"> ▶ When lifting the valve, hang the nylon sling on the neck of the top of the actuator. <div style="text-align: center;">  </div>

 **CAUTION**

 **Prohibition**

The valve may be damaged.

- ▶ Do not over-tighten when piping support is removed with a U-band, etc.
(This will cause damage.)
- ▶ When installing piping, do not install it in the fully closed state. (The disc may get caught in the seat and the operating torque may become heavy, making it impossible to open and close it.)
- ▶ Never transport or install the disc in the condition shown as "impossible" in **Fig. 6-1**, as it will scratch the sealing surface of the disc.
- ▶ Do not tighten the bolt nut for piping with the specified torque or more.
(This may cause leakage or damage.)

 **Forcing**

Risk of injury.

- ▶ Be sure to perform safety inspections of the machine tool and power tool before starting operation.
- ▶ Wear appropriate protective equipment for the work details when installing piping.
(Risk of injury)
- ▶ Do not pull, compress, bend, or apply excessive force to the piping or valve during installation.

Install the product so that no stress is applied to it.
- ▶ Use a connection flange with a full-face seat. If a flange other than the full-face seat (flange adapter/backing flange, etc.) is unavoidably used, depending on the size of the valve, the corner of the flange may bite into the seat and damage the seat. Contact your nearest sales office in advance.
- ▶ Check that the flange standards of each other are correct.
- ▶ When temporarily connecting the valve to a short view, attach the screw bolts (4 bolts on one side and 8 bolts on both sides) to the valve.
- ▶ Fix the bolt nut for piping by tightening it from the through hole. (Failure to do so may result in damage if tightened first from the embedded metal part of the main body.)

⚠ WARNING

- ▶ The product is in the "Good" state as shown in **Fig. 5-1**. Before opening or closing the valve for piping installation, be sure to return the disc to the original condition (Refer to "Good" in **Fig. 5-1**) after operation.
- ▶ If the inner diameter of the connection (flange/pipe) is small, chamfer the inside of the connection to avoid contact between the valve disc and the inner surface of the connection. (See **Fig. 5-2**.)
- ▶ The inner diameter of the connecting part should be equal to or larger than the value shown in **Table 5-1**.

! Forcing

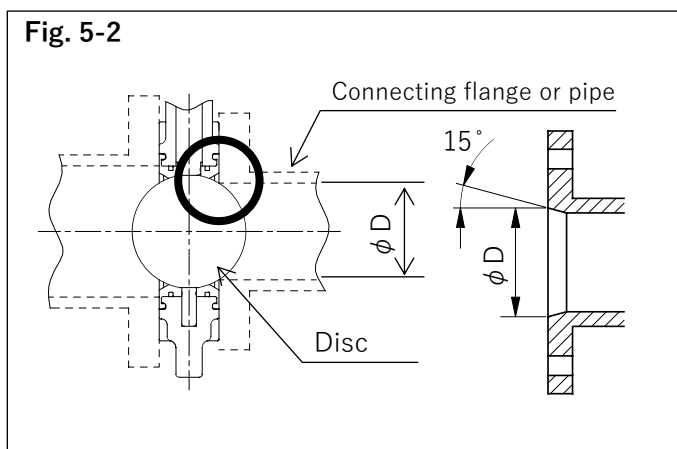
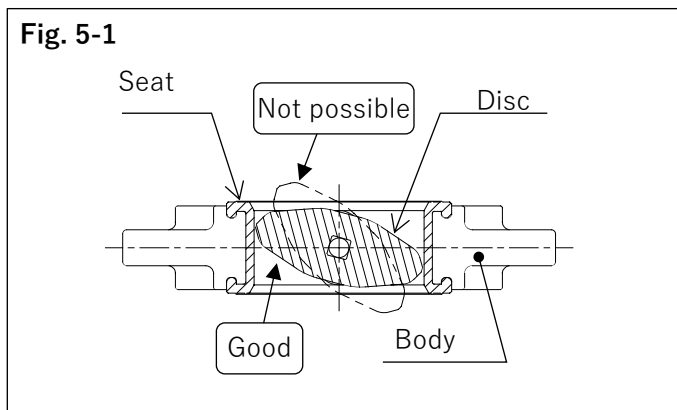

Table 5-1 Minimum bore size

Nominal size	700mm (28")	800mm (32")	900mm (36")
Inner diameter D	677mm (26.65")	777mm (30.59")	877mm (34.53")

Necessary items	▶ Torque wrench	▶ Spanner wrench	▶ Through-bolt	▶ Screw-in bolt
	▶ Nut, Washer	▶ Short pipe	▶ waste cloth	

Dimensions of Through Bolt and Screw-in Bolt

• The length of the bolt to be used varies depending on the connection standard and flange material. Obtain the bolt length using the following formula.

- L : Length of through bolt
- S : Thread length of through bolt
- L1: Length of screw bolt
- D : Nominal thread
- W : Between the surfaces of valves
- a : Thread depth
- b : Flange thickness
- c : Thickness of washer
- d : Thickness of nut
- e : Bolt output (Thread pitch × 3)

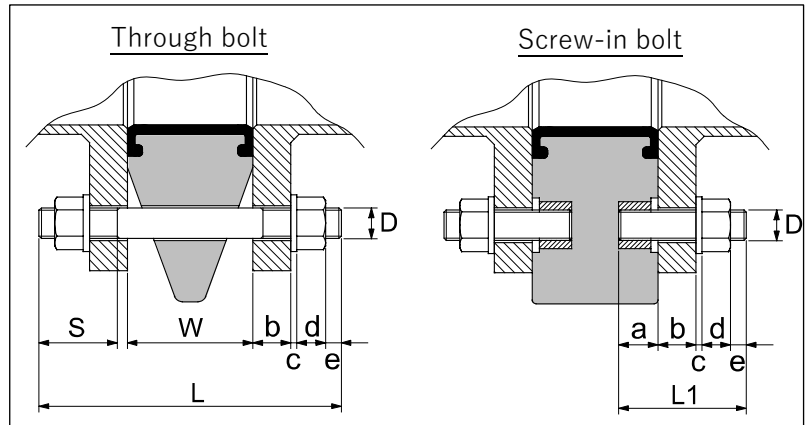

[Through bolt] $L \geq W + (b + c + d + e) \times 2$
 $S \geq D \times 2.5$
 [Screw-in bolt] $L1 \geq a + b + c + d + e$

Nominal size			700mm (28")	800mm (32")	900mm (36")
Common	W	Between valve faces	169mm (6.65")	198mm (7.80")	211mm (8.31")
	D	Thread size	M30	M30	M30
JIS 10K	a	Thread depth	28mm (1.10")	30mm (1.18")	30mm (1.18")
	Q'ty	Through bolt (pcs.)	20	24	24
		Screw-in bolt (pcs.)	8	8	8
		Nut (pcs.)	48	56	56
		Washer (pcs.)	48	56	56
DIN	D	Thread size	M27	M30	M30
	a	Thread depth	28mm (1.10")	30mm (1.18")	30mm (1.18")
	Q'ty	Through bolt (pcs.)	20	20	24
		Screw-in bolt (pcs.)	8	8	8
		Nut (pcs.)	48	48	56
Washer (pcs.)		48	48	56	
ANSI	D	Thread size	UNC 1¼-7	UNC 1½-6	UNC 1½-6
	a	Thread depth	28mm (1.10")	30mm (1.18")	30mm (1.18")
	Q'ty	Through bolt (pcs.)	24	24	28
		Screw-in bolt (pcs.)	8	8	8
		Nut (pcs.)	56	56	64
Washer (pcs.)		56	56	64	

[Procedure]

- 1) Set the short tube in advance. Center and short tube of the valve when the valve was raised. Place the short tube on the pedestal so that the center of the short tube is almost the same, and wipe up the flange surface of the short tube with a waste cloth.
- 2) Raise the valve. Wind the nylon sling around the neck of the valve to gradually raise the valve and wipe up the inner surface of the valve with a waste cloth.

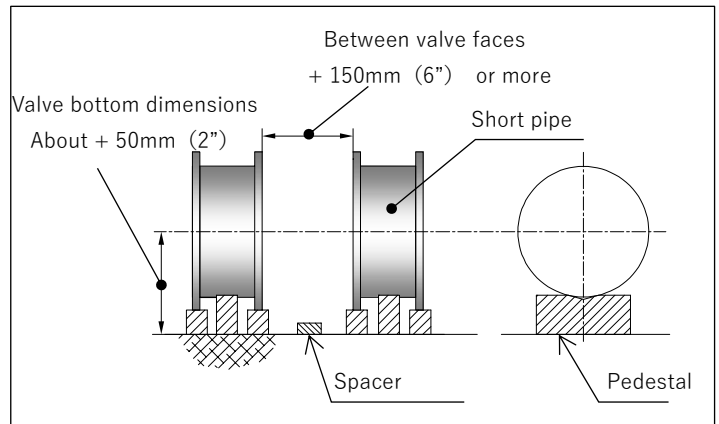

- 3) Gradually lower the valve between the set short pipes.
- 4) Temporarily connect the short pipe and the valve. Slightly adjust the valve or short tube so that the bolt holes of the short tube generally matches the bolt hole of the valve. Move it. At this time, take the screw bolts (4 on one side and 8 on both sides) to the valve. Adjust the position of the bolt holes.

- 5) Install the through bolt and lightly tighten the nut.
- 6) After installing all the bolts lightly, gradually tighten only the through bolts to the specified torque value diagonally with a torque wrench. (See **Table 5-2** and **Figure 5-3**.)
- 7) After completing the tightening of the through bolts, gradually tighten the screw-in bolts diagonally to the specified torque value with a torque wrench. (See **Table 5-2** and **Figure 5-3**.)
- 8) Tighten all pipe bolts clockwise to the specified torque value for at least two turns. (See **Table 5-2** and **Figure 5-3**.)

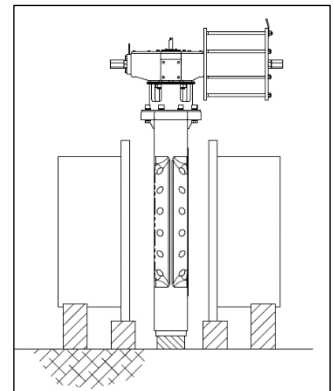
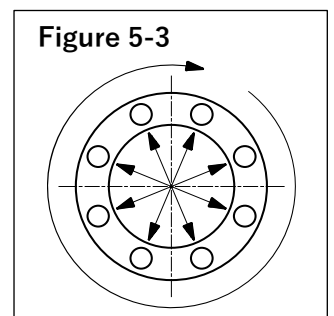





Table 5-2 Flange tightening torque

Nominal size	700mm (28")	800mm (32")	900mm (36")
Tightening torque N-m {kgf-cm}	130 {1,330}	130 {1,330}	170 {1,740}



Product support

 WARNING	
 Prohibition	<p>The valve may be damaged or broken.</p> <p>▶ Do not cause large vibrations to the valve by the piping around the pump.</p>
 Forcing	<p>Damage to the valve body and piping may occur.</p> <p>▶ Install a valve support.</p>

Necessary items	▶ Spanner wrench	▶ U-band (with bolt)	▶ Rubber sheet
-----------------	------------------	----------------------	----------------

Horizontal piping

[Procedure]

- 1) Place the frame under the valve.
- 2) Place a rubber sheet under the actuator, Support by the frame.
- 3) With a rubber sheet on the pipe and a U-band Fix it.

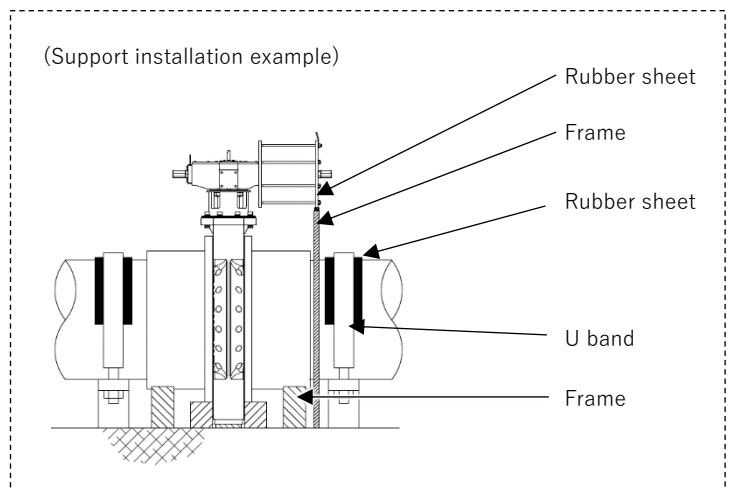



Vertical piping

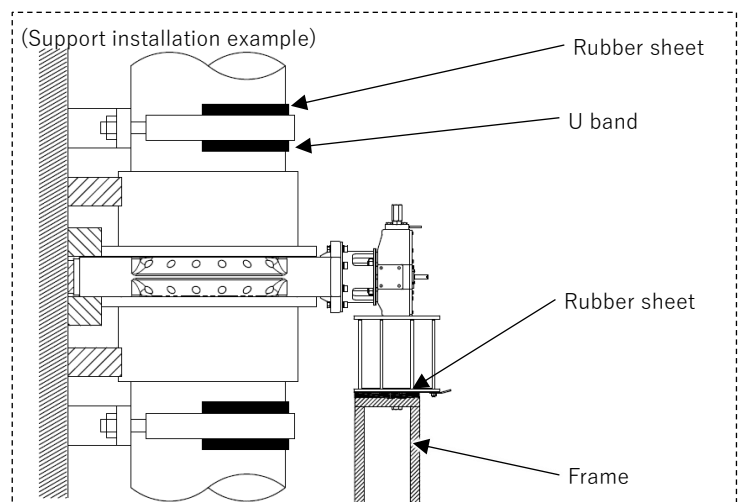

[Procedure]

- 1) Place a rubber sheet under the actuator, Support by the frame.
- 2) With a rubber sheet on the pipe and a U-band Fix it.



6. Electrical Wiring

 WARNING	
 Prohibition	<p>There is a risk of electric shock or injury.</p> <ul style="list-style-type: none"> ▶ Do not connect or separate lines when the power is on. Also, do not touch any other parts on the PCB or the terminal block wiring part. ▶ Never touch the moving parts during operation.
 Forcing	<p>There is a risk of electric shock or injury.</p> <ul style="list-style-type: none"> ▶ Be sure to connect the ground wire. ▶ Keep hands free of moisture and oil when adjusting or checking. ▶ Perform manual operation after confirming that the actuator is not operated by the motor.

 CAUTION	
 Prohibition	<p>Doing so may cause malfunction or failure.</p> <ul style="list-style-type: none"> ▶ Do not connect multiple (two or more) motorized valves in series. Install an open/close switch (or relay contact) for each electric valve. ▶ Do not use the product near high-voltage lines, inverters, or other objects that generate noise or magnetism.
 Forcing	<p>Doing so may cause malfunction or failure.</p> <ul style="list-style-type: none"> ▶ Do not apply a load to the non-voltage limit switch exceeding the contact capacity. ▶ Check that there is no insulation defect when performing wiring work. ▶ Securely tighten the covers of each part. ▶ Be sure to connect the wires correctly according to the wiring diagram. After wiring, be sure to check that the connection is secure, and then turn on the power. ▶ The lids are sealed by O rings. When removing and reattaching the cover for wiring, etc., be sure to confirm that O ring is set in place and sealed securely. ▶ If the actuator is used outdoors or in a location where it will be exposed to rainwater or water drops, make sure that rainwater does not enter the actuator through the wiring port. ▶ Make sure that the power voltage indicated on the nameplate of the actuator matches the voltage you intend to wire.



Necessary items	<ul style="list-style-type: none"> ▶ Hexagon wrench ▶ Wire stripper ▶ Actuator manufacturer (auma) Instruction manual (supplied) 	<ul style="list-style-type: none"> ▶ Phillips screwdriver ▶ terminal Crimp tool 	<ul style="list-style-type: none"> ▶ Flat head screwdriver ▶ Crimp terminal
-----------------	---	---	---

[Procedure]

Perform the electric wiring according to the instruction manual supplied with the actuator manufacturer (auma).

7. Commissioning method



Manual operation



 CAUTION	
 Prohibition	<p>Doing so may cause malfunction or failure.</p> <ul style="list-style-type: none"> ▶ Do not force the handle to rotate further from the fully opened or closed position.
 Forcing	<p>Doing so may cause malfunction or failure.</p> <ul style="list-style-type: none"> ▶ Perform the operation after confirming that the actuator is not being operated by the motor.

[Procedure]

Follow the instructions provided by the actuator manufacturer (auma).

Automatic operation

 WARNING	
 Prohibition	<p>There is a risk of electric shock or injury.</p> <ul style="list-style-type: none"> ▶ Never touch the moving parts during operation. ▶ Do not leave the actuator cover open.
 Forcing	<p>There is a risk of electric shock or injury.</p> <ul style="list-style-type: none"> ▶ Be sure to connect the ground wire. ▶ Keep hands free of moisture and oil when adjusting or checking.

 CAUTION	
 Prohibition	<p>Doing so may cause malfunction or failure.</p> <ul style="list-style-type: none"> ▶ Do not connect multiple (two or more) motorized valves in series. Install an open/close switch (or relay contact) for each electric valve. ▶ Do not use the product near high-voltage lines, inverters, or other objects that generate noise or magnetism.
 Forcing	<p>Doing so may cause malfunction or failure.</p> <ul style="list-style-type: none"> ▶ Do not apply a load to the non-voltage limit switch exceeding the contact capacity. ▶ Securely tighten the covers of each part. ▶ Be sure to connect the wires correctly according to the wiring diagram. After wiring, be sure to check that the connection is secure, and then turn on the power. ▶ The lids are sealed by O-rings. When removing and reattaching the cover for wiring, etc., be sure to confirm that O-ring is set in place and sealed securely. ▶ If the actuator is used outdoors or in a location where it will be exposed to rainwater or water drops, make sure that rainwater does not enter the actuator through the wiring port. ▶ Make sure that the power voltage indicated on the nameplate of the actuator matches the voltage you intend to wire.

[Procedure]

Follow the instructions provided by the actuator manufacturer (auma).

8. How to adjust the limit switch

 **WARNING**



Prohibition

There is a risk of electric shock or injury.

- ▶ Do not connect or disconnect wires to the limit switch while the power is on.

 **CAUTION**



Prohibition

Doing so may cause malfunction or failure.

- ▶ Do not leave or use the cover open.



Necessary
items

- ▶ Hexagon wrench
- ▶ Flat head screwdriver
- ▶ Actuator manufacturer (auma) Instruction manual (supplied)

[Procedure]

Adjust the limit switch according to the instruction manual supplied by the actuator manufacturer (auma).

9. Inspection item

 CAUTION	
 Forcing	<p>Leakage may occur due to changes in temperature or aging during long-term storage, resting, or use.</p> <p>▶ Please enforce daily inspection and periodic inspection.</p>

Daily inspection

Inspection items and method	Guideline of judgment	Check point	Treatment method
External leakage (visual inspection)	For leakage No	Pipe flange connection	<ol style="list-style-type: none"> 1) Retighten the pipe bolts to the specified torque. 2) Remove the valve from the pipe and re-tighten the pipe bolts.
		Top flange and bottom flange of the valve	Remove the valve from the pipe and replace the valve.
		Surface of the entire valve	Remove the valve from the pipe and replace the valve.
Internal leakage (visual and measurement)	For leakage No	Leakage to secondary side when valve is fully closed	<ol style="list-style-type: none"> 1) Adjusting the actuator limit position 2) Inspection and cleaning of sealing surfaces 3) Remove the valve from the pipe and replace the valve.
		Measured values of flowmeters, pressure gauges, etc.	<ol style="list-style-type: none"> 1) Adjusting the actuator limit position 2) Inspection and cleaning of sealing surfaces 3) Remove the valve from the pipe and replace the valve.
Operating position Displacement (visual inspection)	In a shift No	Actuator opening display	<ol style="list-style-type: none"> 1) Adjusting the actuator limit position 2) Replace actuator or valve

Daily Inspection (continued)

Inspection items and method	Guideline of judgment	Check point	Treatment method
Abnormal noise (hearing)	Abnormal noise No	Valves and actuators	Remove the valve from the pipe and replace the valve or actuator.
		Piping around the valve	Reconfirm the conditions of use
Unusual odor (sniffing)	With a strange smell No	Valves and actuators	Remove the valve from the pipe and replace the valve or actuator.
Valve damage	No cracks	Surface of the entire valve	Remove the valve from the pipe and replace the valve.

Periodic inspection
***Guideline for the inspection cycle: 3 months**

Inspection items and method	Guideline of judgment	Check point	Remedy for malfunctions
Opening and closing Operating time (Measurement)	Error within ± 3 second	Actuator opening display	Check the power supply voltage ($\pm 10\%$).
			Remove the valve from the pipe and replace the valve or actuator.
Vibration (palpation)	To differences from other parts No	Valves and actuators	Recheck the operating conditions and remove the source of vibration.
			Remove the valve from the pipe and replace the valve or actuator.
		Piping around the valve	Recheck the operating conditions and remove the source of vibration.

*** Guideline of the inspection cycle: 6 months**

Inspection items and method	Guideline of judgment	Check point	Remedy for malfunctions
On the manual handle Operability (touch)	Smoothly Turning	Manual operation unit	Remove the valve from the pipe and replace the valve or actuator.
Of bolts Looseness (visual and palpation)	Loose No	For actuator + valve	Retighten the mounting screws with a 100 N-m.
		For flange piping	Retighten the pipe bolts to the specified torque.
Water intrusion (visual inspection)	Of the intrusion No	Inside the actuator	Replace the actuator
Entry of foreign matter (visual inspection)	Of the intrusion No	Inside the actuator	Replace the actuator
Measurement of insulation resistance (Measurement)	50 M Ω or more Having	Inside the actuator	Replace the actuator
Corrosion Or rust (visual inspection)	Corrosion or Of rust No	Appearance of the product and in the actuator	Remove the valve from the pipe and replace the valve or actuator.
Product damage	No scratches, cracks, or deformation	Appearance of the product	Remove the valve from the pipe and replace the valve or actuator.

10. Troubleshooting

Problem	Cause	Treatment
The handle does not turn (cannot turn) during manual operation.	The valve is already fully open (or fully closed).	Rotate the handle in the opposite direction.
	The power remains supplied in the opposite direction of the handle operation direction.	Turning the power off and then manually operating.
	Foreign matter caught in valve	Remove the valve from the piping, disassemble it, and remove foreign matter.
	Piping stress is applied to the valve.	Remove the piping stress
	The torque of the valve has increased due to the effects of the fluid (temperature, components, pressure, etc.)	Reconfirm the conditions of use
Do not open or close with electric operation	The power is off.	Check the voltage and turn on the power.
	Wiring to the terminal block is disconnected.	Stop operation immediately and recheck the connection status.
	The cable or the connection inside the actuator is broken.	Replace the cable or the actuator.
	Simultaneous switching energizing or incorrect wiring to the terminal block	Stop operation immediately and recheck the connection status.
	The power supply voltage is different.	Check the voltage with a tester to obtain the correct voltage.
	Power supply voltage is low.	Check the voltage with a tester to obtain the correct voltage.
	Foreign matter caught in valve	Remove the valve from the piping, disassemble it, and remove foreign matter.

Troubleshooting (continued)

Problem	Cause	Treatment
Do not open or close with electric operation	Piping stress is applied to the valve.	Remove the piping stress
	The torque of the valve has increased due to the effects of the fluid (temperature, components, pressure, etc.)	Reconfirm the conditions of use
	The thermal protector is activated.	Stop using the product immediately, and lower the ambient temperature or the opening/closing frequency.
	The capacitor is burnt out (punctured).	Stop using the product immediately and replace the actuator.
	Water or foreign matter has entered the actuator causing a short circuit.	Stop using the product immediately and replace the actuator.
	The actuator does not move due to external corrosion of the actuator.	Stop using the product immediately and replace the actuator.
	The insulation resistance of the actuator has dropped.	Stop operation immediately, check the insulation resistance, and replace the actuator.
Fluid leaks even when fully closed (internal leak)	High fluid pressure	Use below the maximum allowable pressure.
	Seat or disc is worn or scratched	Remove the valve from the pipe and replace the valve.
	Missing parts	Remove the valve from the pipe and replace the valve.
	Foreign matter caught in valve	Remove the valve from the piping, disassemble it, and remove foreign matter.
	Piping stress is applied to the valve.	Remove the piping stress

Troubleshooting (continued)

Problem	Cause	Treatment
Fluid leaks from valve (external leak)	O-ring is scratched, worn, melted, or altered	Stop using the product immediately, remove the valve from the piping, and replace the valve.
	Scratches or wear are found on the sliding or fixing surfaces of the O-ring.	Stop using the product immediately, remove the valve from the piping, and replace the valve.
	Valve is cracked or broken	Stop using the product immediately, remove the valve from the piping, and replace the valve.
Actuator is operating but valve is not open or closed	Damaged stem or fitting	Stop using the product immediately, remove the valve from the piping, replace the relevant part, or replace the valve.
The actuator emits a bad smell, heat, or smoke.	Actuator is defective	Stop using the product immediately, remove the valve from the piping, and replace the actuator.
	Wrong connection to the terminal block	Stop using the product immediately, remove the valve from the piping, and replace the actuator.
	An overcurrent is flowing to the actuator	Stop using the product immediately, remove the valve from the piping, and replace the actuator.
	The actuator is affected by lightning.	Stop using the product immediately, remove the valve from the piping, and replace the actuator.
Actuator is corroded	The watch is exposed to water, chemical liquids, or other liquids.	Stop using the product immediately, remove the valve from the piping, and replace the actuator.
Valve is corroded or deformed	The watch is exposed to water, chemical liquids, or other liquids.	Stop using the product immediately, remove the valve from the piping, and replace the valve.

11. How to inquire about defects or replacement **CAUTION** **Forcing****When burnt, toxic gas is generated.**

- ▶ When disposing of the product or parts, please dispose of them according to the guidelines of each local authority by a professional disposal company.

Contact

Contact the nearest distributor, our sales office, or our web website for inquiries about this product.

[User's Manual]

Butterfly valve type 58 Electric Actuated

Type A

700mm (28") ~ 900mm (36")



The product names, logos, and other trademarks mentioned in this instruction manual are all registered trademarks of ASAHI YUKIZAI CORPORATION.

These trademarks are the intellectual property of ASAHI YUKIZAI CORPORATION and may not be used without permission.

Nothing in this manual grants a license to use the trademarks, either expressly or implicitly.

For further details regarding registered trademarks, please contact ASAHI YUKIZAI CORPORATION.

<https://www.asahi-yukizai.co.jp/en>

Please note that the content of this manual is subject to change without notice.

May 2026

[User's Manual] Butterfly valve Type 58 Electric Actuated Type A 700mm (28") ~ 900mm (36")